



**CHEMSUN**  
PROZESS UND REGELTECHNIK



**高性能金属密封蝶阀**

智控技术领域引领者



Wetterau

# ABOUT US

## 关于我们

CHEMSUN EUROPE GMBH坐落于德国莱茵-美茵大经济区中奥芬巴赫工业区的企业，毗邻美茵河畔法兰克福，距离法兰克福机场仅约十公里，工业气息浓厚、交通便捷。CHEMSUN秉承了悠久厚重的德国工业品质和文化，在恪守严谨传统德国制造的基础上，不断技术创新，在流体控制领域专注耕耘多年，积累了雄厚的研发和加工能力以及丰富的工业现场经验，是工业流体智控的引领者。

CHEMSUN有三大产品板块：电动执行机构、工业控制阀、气动仪表和气电集成控制系统。公司产品凭借其优良的品质、卓越的可靠性、齐全而独特的功能，为客户提供应对苛刻工业工况的整体解决方案，广泛地服务于油气、化工、电力、盾构制造、市政暖通与空调、冶金和轻工等行业领域。

凯姆斯智控北京公司是2015年成立于北京CBD的研发和生产型企业，专业为中国客户提供公司产品、技术支持、维修和现场服务。

我们的理念：源自德国、立足中国、服务全球。

CHEMSUN 值得信赖的品牌！

## 蝶阀型号编制方法 Method to work out the model of butterfly valve

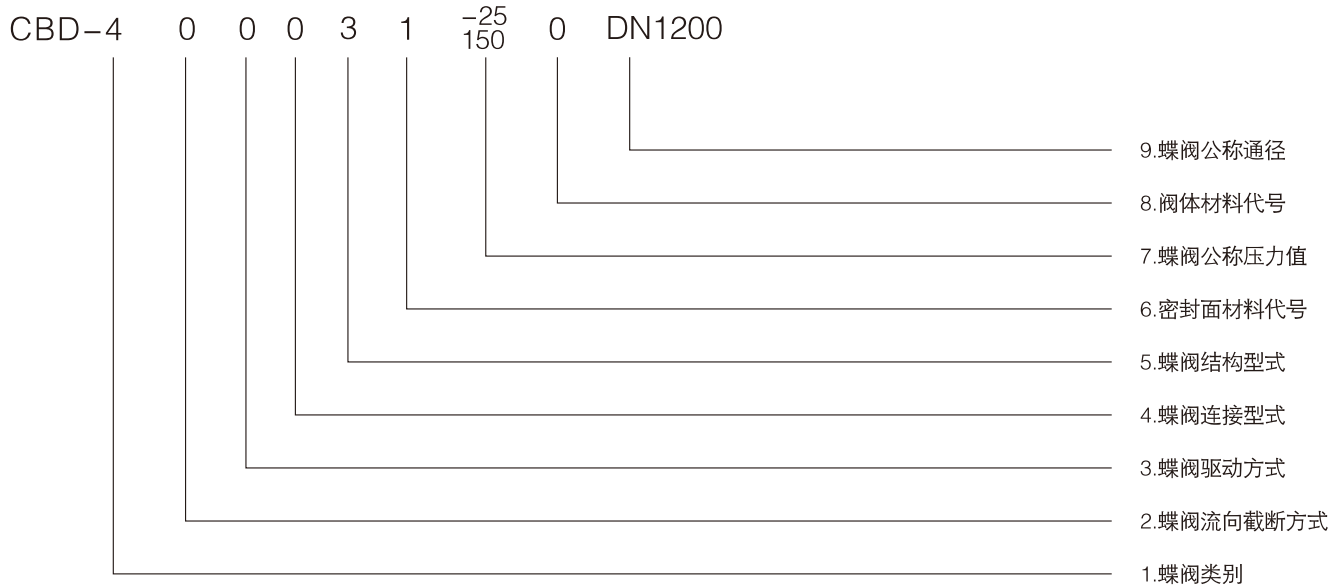

### 1. 蝶阀类别 Type of butterfly valve

1	2	3	4	5
低温 ( $\leq -40^{\circ}\text{C}$ ) Low temperature	保温 Heat preservation	伸缩蝶阀 Telescopic butterfly valve	高性能蝶阀 High performance butterfly valve	真空蝶阀 Vacuum butterfly valve

### 2. 蝶阀流向截断方式 Butterfly valve flowing direction cutoff mode

0	1
可任意流向截断介质的蝶阀 (双向压) Butterfly valve which can cut off the medium at any flowing direction (bi-way pressure)	只能按指示流向截断介质的蝶阀 (单向压) Butterfly valve which can cut off the medium only upon the indicated flowing direction (single-way pressure)

### 3. 蝶阀驱动方式 Butterfly valve actuation mode

0	1	2	3
蜗轮装置驱动 Worm gear actuator drive	气动装置驱动 Pneumatic actuator drive	电动装置驱动 Electric actuator drive	液动装置驱动 Hydraulic actuator drive

### 4. 蝶阀连接型式 Butterfly valve connection type

0	1	2	3
法兰式 Flanged type	对焊式 Butt weld type	对夹式 Wafer type	凸耳式 Lug type

### 5. 蝶阀结构型式 Butterfly valve structure type

2	3	4
双偏心 Double eccentric	三偏心 Triple eccentric	四偏心 Four eccentric

### 6. 密封面材料代号 Code of sealing surface material

1	2	3	4	5
Cr13系不锈钢 Stainless steel	硬质合金 Cemented carbide	橡胶 Rubber	氟塑料 Fluorine plastic	本体材料 Body material



**7. 蝶阀公称压力值PN value of butterfly valve**

用MPa的10倍值表示 Expressed with 10 times of MPa value
用磅级表示 Expressed with grade of pound

**8. 阀体材料代号Code of body material**

0	1	2	3	4	5	6
碳钢 Carbon steel	铬镍系不锈钢 CrNi stainless steel	铬镍钼不锈钢 CrNiMo stainless steel	铬钼系钢 CrMo steel	钛及钛合金 Titanium and titanium alloy	合金钢 Alloy steel	铬钼钒钢 CrMoV steel

**9. 蝶阀公称通径DN of butterfly valve**

DN(mm)	inch	DN(mm)	inch	DN(mm)	inch	DN(mm)	inch
80	3	350	14	900	36	2200	88
100	4	400	16	1000	40	2400	96
125	5	450	18	1200	48	2600	104
150	6	500	20	1400	56	2800	112
200	8	600	24	1600	64	3000	120
250	10	700	28	1800	72	3200	128
300	12	800	32	2000	80	3400	136

## 执行标准 Execution standard

**设计与制造:**

API609、ASME B16.34 等标准

**连接法兰:**

ASME B16.5、ASME B16.47 等标准

**结构长度:**

API609、ISO5752 等标准

**检验与试验:**

API598、ISO5208等标准

**Design and manufacturing:**

API609, ASME B16.34 and standard

**Connecting flange:**

ASME B16.5, ASME B16.47, and standard

**Structure length:**

API609, ISO5752 and standard

**Inspection and test:**

API598, ISO5208, and standard

## 适用范围 Scope of application

**公称通径:**

DN50~DN3600 2"~144"

(不同阀门类型尺寸范围有所不同, 详情请电询)

**公称压力:**

PN2.5~PN260 Class150~Class1500

(不同阀门类型压力范围有所不同, 详情请电询)

**温度范围:**

-196℃~600℃

**连接方式:**

法兰式、对焊式、对夹式、凸耳式等

**主体材料:**

碳钢、铬钼钢、奥氏体不锈钢、双相不锈钢、钛合金、哈氏合金、蒙乃尔合金等。

**Nominal size:**

DN50~DN3600 2"~144"

(Different valve type size range is different, the details please call ask)

**Nominal pressure:**

PN2.5 ~ PN260 Class150 ~ Class1500

(Different valve type pressure range is different, the details please call ask)

**Temperature range:**

-196 °C ~ 600 °C

**Connection:**

flange, butt welding type, wafer, lug type, etc

**Main material:**

carbon steel, chrome molybdenum steel, austenitic stainless steel, duplex stainless steel, Titanium alloy, hartz alloy, monel alloy, etc.



主要零件分解图 Main parts diagram

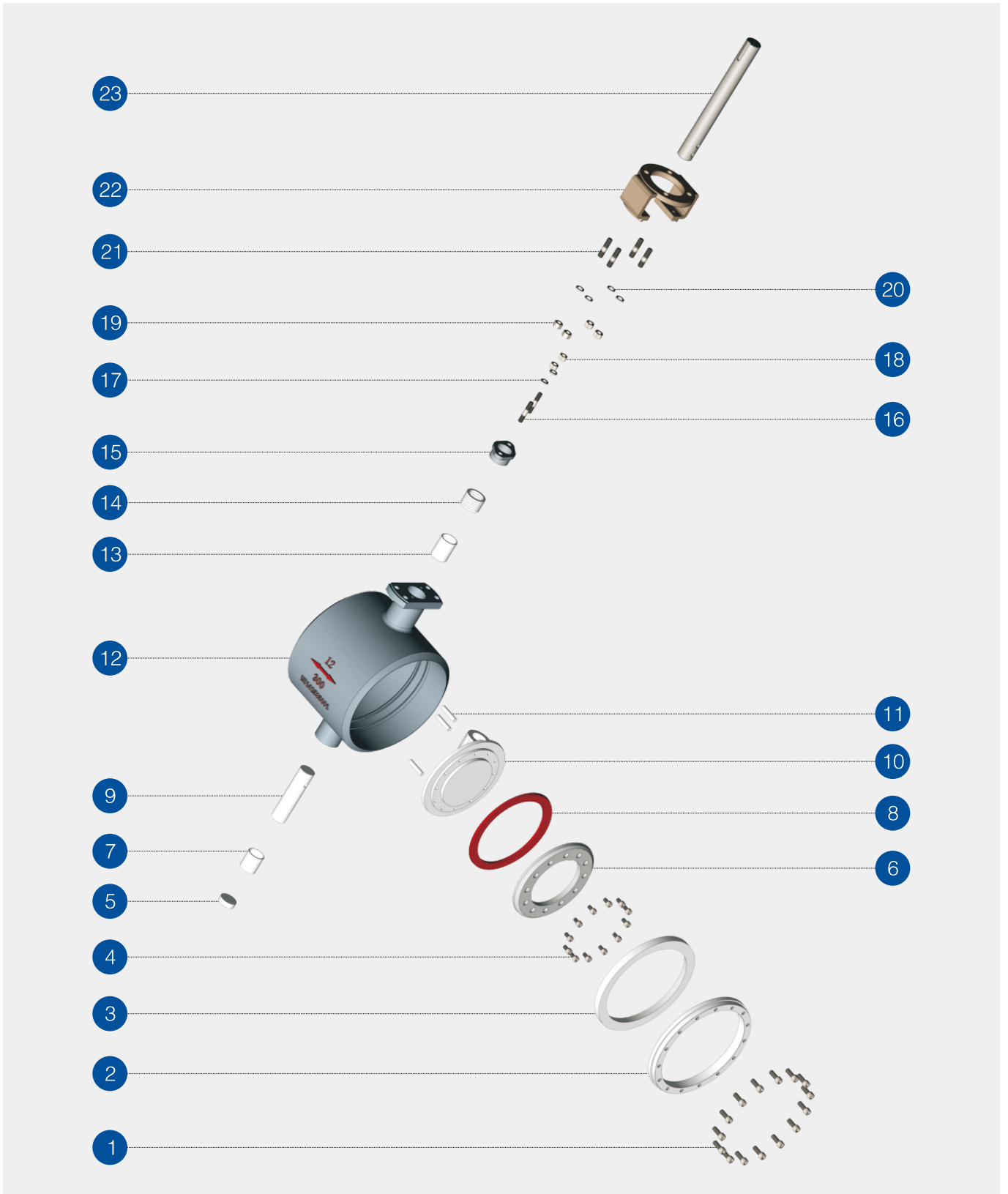

## 主要零件材质表 Main parts material table

序号 ITEM	零件名称 Component	碳素钢阀门零件材料 Carbon Steel		不锈钢阀门零件材料 Stainless Steel	
		国标GB	美标API	国标GB	美标API
1	内六角螺栓 Hex Head	8.8级	ASTM A193 B7	06Cr19Ni10	ASTM A320 B8
2	对开环 Connector Ring	25	ASTM A105	06Cr19Ni10	ASTM A182 F304
3	阀座 Seat	2Cr13	ASTM A276 420	06Cr19Ni10+STL	ASTM A182 F304+STL
4	内六角螺栓 Hex Head	8.8级	ASTM A193 B7	06Cr19Ni10	ASTM A193 B8
5	端盖 Flang	25	ASTM A105	06Cr19Ni10	ASTM A182 F304
6	压环 Disc Pressure Ring	25	ASTM A105	06Cr19Ni10	ASTM A182 F304
7	下轴套 Sleeve	06Cr19Ni10	ASTM A276 304	06Cr19Ni10	ASTM A276 304
8	密封环 Seal Ring	06Cr19Ni10+ Graphite/PTFE/Carbon fibre	ASTM A182 F304+ Graphite/PTFE/Carbon fibre	06Cr17Ni12Mo2+ Graphite/PTFE/Carbon fibre	ASTM A276 304+ Graphite/PTFE/Carbon fibre
9	下阀杆 Shaft	20Cr13	ASTM A276 420	05Cr17Ni4Cu4Nb	ASTM A564 630
10	蝶板 Disc	WCB	ASTM A216 WCB	CF8	ASTM A351 CF8
11	销 Pin	20Cr13	ASTM A276 420	06Cr19Ni10	ASTM A564 630
12	阀体 Body	WCB	ASTM A216 WCB	CF8	ASMT A351 CF8
13	上轴套 Sleeve	06Cr19Ni10	ASTM A276 304	06Cr19Ni10	ASTM A276 304
14	填料 Packing	Graphite/PTFE	Graphite/PTFE	Graphite/PTFE	Graphite/PTFE
15	填料压盖 Packing Gland	WCB	ASTM A216 WCB	CF8	ASTM A351 CF8
16	压盖螺栓 Gland stud	8.8级	ASTM A193 B7	06Cr19Ni10	ASTM A193 B8
17	弹性垫圈 Washer	65Mn	ASTM A29 1566	06Cr19Ni10	ASTM A29 1566
18	螺母 Gland Nut	8级	ASTM A194 2H	06Cr19Ni10	ASTM A194 8
19	螺母 Gland Nut	8级	ASTM A194 2H	06Cr19Ni10	ASTM A194 8
20	弹性垫圈 Washer	65Mn	ASTM A29 1566	06Cr19Ni10	ASTM A29 1566
21	支架螺栓 Yoke Stud	8.8级	ASTM A193 B7	06Cr19Ni10	ASTM A193 B8
22	支架 Yoke	WCB	ASTM A216 WCB	WCB	ASTM A216 WCB
23	上阀杆 Shaft	20Cr13	ASTM A276 420	05Cr17Ni4Cu4Nb	ASTM A564 630

◆ 不同材质阀门各零件材质不同，详情请电询 Different material valve parts material is different, the details please call ask

## 全金属双向压蝶阀 Full metal-seated bi-directional butterfly valve

### 产品主要特点 Product main features

#### ● 超长寿命设计 Long life design

阀座/密封圈完全由金属材料制成，且做表面硬化处理，就算启闭频繁，阀门仍能保持高的密封性能，杜绝了多层次密封结构不耐冲刷等弊端，极大提高了阀门的使用寿命；

The seat/seal ring is completely made of metal materials and dealt with surface hardening treatment so that the valve can be under high sealing performance even open/close with high frequency. Long life design protects the multi-layer sealing structure from eroding and other shortcomings, greatly improve the service life of the valve.

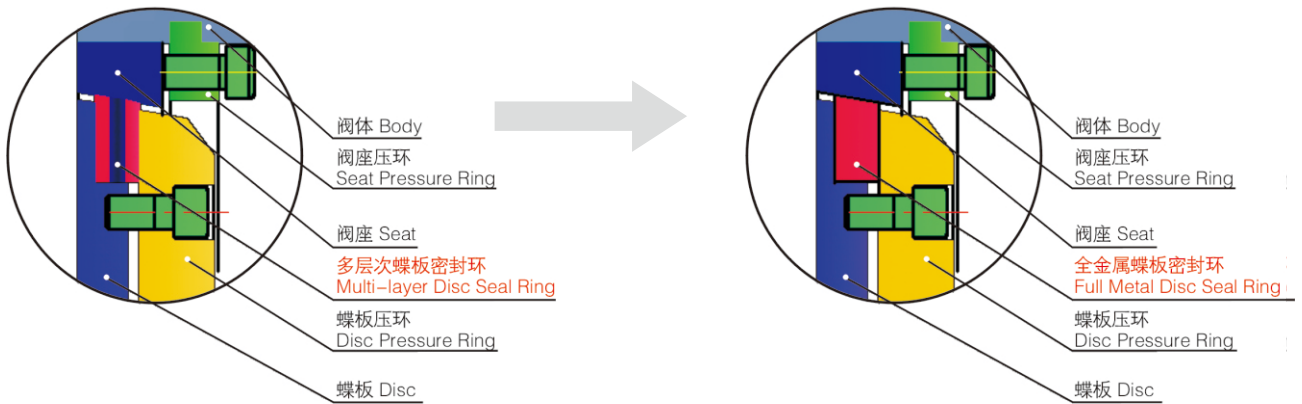

#### ● 依靠扭矩密封 Sealing with Torque

阀门至始至终都能保持优越的双向密封性能，阀门密封不依靠介质力，完全由驱动装置提供的扭矩实现密封，阀门在高、低压下均能可靠密封。密封性能检测结果符合API609、ISO5208等标准之规定；

Sealing with torque keeps valve having superior two-way sealing performance. Valve completely sealed by torque of the actuator rather than forces produced by media, which makes valve sealed under high and low pressure unfailingly. Sealing performance test results meet the requirement of the API609, ISO5208 and other Standards that concerns.

#### ● 本质防火设计 Essence of fire protection

全金属密封副结构，使阀门具有本质防火特性，且测试结果符合API607的规定；

Full metal sealing structure makes valve carry the property of fire protection and the test results comply with the provisions of the API607 Standard.

#### ● 阀座/密封圈可现场更换 Seat/sealing ring can be replaced on field

可更换式阀座/密封圈设计，便于阀门现场维护保养。

Replaceable seat/sealing design makes valve easily maintained on field.

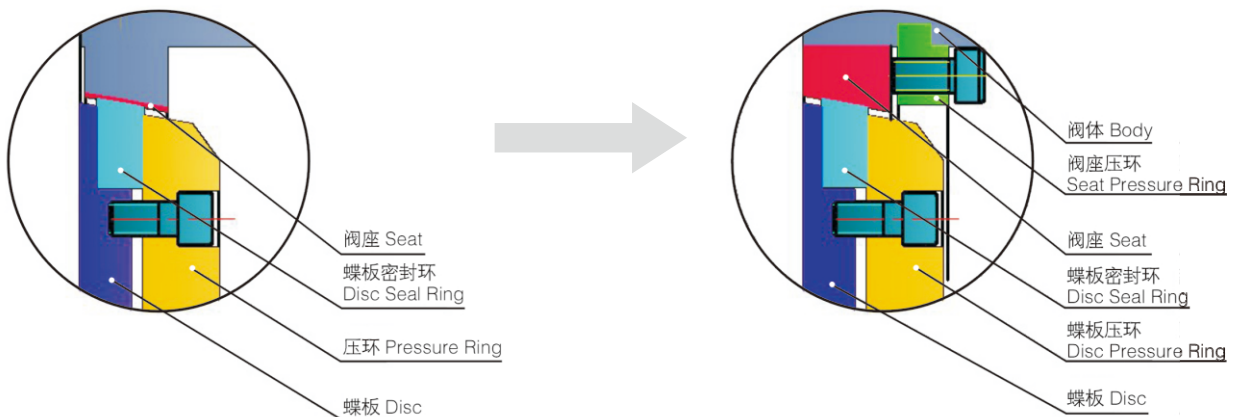



## 高性能双向压供热蝶阀 High performance bi-directional heating butterfly valve

### 产品主要特点 Product main features

- 阀门采用三偏心结构，即在普通金属硬密封双偏心蝶阀的基础上增加了一个角度偏心。这个角度偏心的主要作用是：使阀门在开启或关闭动作的过程中，密封环与阀座之间的任意一点都会迅速脱离或接触，做到密封副之间真正的“无摩擦”，极大地延长了阀门的使用寿命；

The valve uses a three-cam structure, that means an angular cam is added to a common metal hard seal bi-cam butterfly valve. This angular cam functions: to have any point between the seal ring and the seat ring quickly separated off or contacted during the valve open or close action to leave a true "non-friction" between the seal pairs, greatly extending the valve life.

- 高性能双向压供热蝶阀采用了含有国家专利技术的“径向动平衡密封系统”，通过优化设计，蝶板的进出口两侧受力近似平衡，阀门达到进出口双向可靠的密封性能的同时，有效降低了阀门的开启力矩（约为普通蝶阀的2/3）；
- The high performance bi-directional heating butterfly valve uses a "radial dynamically balanced sealing system" of the national patented technology and, by means of optimized design, both sides of the butterfly plate inlet and outlet are stressed approximately balanced to effectively lower the valve opening moment (about 2/3 of the common butterfly valves) at the same time to have the valve a reliable sealing performance on both inlet and outlet.

- 蝶板密封环由片状不锈钢和碳纤维材料复合而成，不锈钢片为主密封，碳纤维为辅助密封，这种双重密封结构，使阀门密封更可靠，密封泄漏等级可达ASME B16.104 VI级或ISO5208 A级；

The seal ring of the butterfly plate is made up with sheet stainless steel and carbon fiber by way of compounding, with the stainless steel sheet as the primary seal and the carbon fiber as the assisting one. This dual-sealing structure makes the valve more reliably sealed and the seal leaking grade up to ASME B16.104 VI or ISO5208A.

- 碳纤维夹层材料与普通供热蝶阀的橡胶石棉板、石墨等材质的夹层相比，具有更环保、更耐磨、更耐冲刷、更可靠等特点，可达20万次无故障启闭；
- Compared to the sandwich of the common heat supply butterfly valve made of rubber asbestos plate, graphite etc materials, that of the carbon fiber sandwich features more environmental protection, more wearable, more resisting to scouring and more reliable, up to 200,000 times of non-failure open-close.

- 高性能双向供热蝶阀与管道通常采用焊接的方式连接，能彻底消除其它连接方式常见的垫片处泄漏等弊端，使阀门在井下安全运行；
- A welded connection way is usually used between the high performance bi-directional heating butterfly valve and the pipeline. This can completely eliminate the gasket leaking etc. problems commonly with the other connection ways to have the valve safely working in the well.

- 高性能双向压供热蝶阀的端盖与阀体采用焊接连接，与普通用螺栓固定下端盖的供热蝶阀相比，这种设计的最大特点是，能杜绝下端盖与阀体连接处的渗漏，阀门运行更可靠。

A welded connection way is used between the end cover and the body of the high performance bi-way heat supply butterfly valve and, compared to the common heat supply butterfly valve which uses a bolt to fix the lower end cover, what is the biggest feature with this design is able to put an end to the leaking at the connection between the lower end cover and the body, leaving the valve more reliably workable.

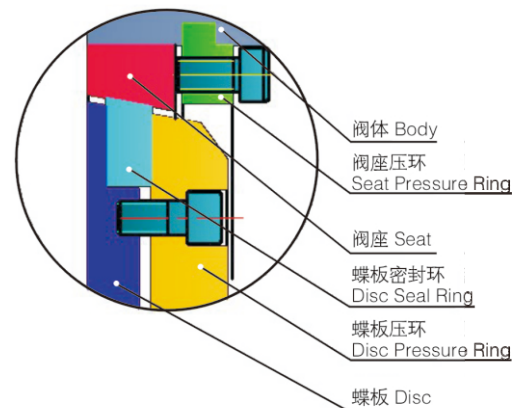

## 高性能双向压真空蝶阀 High performance bi-directional vacuum butterfly valve 高性能双向压燃气蝶阀 High performance bi-directional gas butterfly valve

### 产品主要特点 Product main features

- 阀门采用三偏心结构，即在普通金属硬密封双偏心蝶阀的基础上增加了一个角度偏心。这个角度偏心的主要作用是：使阀门在开启或关闭动作的过程中，密封环与阀座之间的任意一点都会迅速脱开或接触，做到密封副之间真正的“无摩擦”，极大地延长了阀门的使用寿命；

The valve uses a three-cam structure, that means an angular cam is added to a common metal hard seal bi-cam butterfly valve. This angular cam functions: to have any point between the seal ring and the seat ring quickly separated off or contacted during the valve open or close action to leave a true "non-friction" between the seal pairs, greatly extending the valve life.

- 高性能双向压真空蝶阀/燃气蝶阀采用了含有国家专利技术的“径向动平衡密封系统”，通过优化设计，蝶板的进出口两侧受力近似平衡，阀门达到进出口双向可靠的密封性能的同时，有效降低了阀门的开启力矩（约为普通蝶阀的2/3）；

The high performance bi-directional vacuum butterfly valve/gas butterfly valve uses a "radial dynamically balanced sealing system" of the national patented technology and, by means of optimized design, both sides of the butterfly plate inlet and outlet are stressed approximately balanced to effectively lower the valve opening moment (about 2/3 of the common butterfly valves) at the same time to have the valve a reliable sealing performance on both inlet and outlet.

- 蝶板密封环由片状不锈钢和碳纤维材料复合而成，不锈钢片为主密封，碳纤维为辅助密封，这种双重密封结构，使阀门密封更可靠，密封泄漏等级可达ASME B16.104 VI级或ISO5208 A级；

The seal ring of the butterfly plate is made up with sheet stainless steel and carbon fiber by way of compounding, with the stainless steel sheet as the primary seal and the carbon fiber as the assisting one. This dual-sealing structure makes the valve more reliably sealed and the seal leaking grade up to ASME B16.104 VI or ISO5208A.

- 碳纤维夹层材料与普通蝶阀的橡胶石棉板、石墨等材质的夹层相比，具有更环保、更耐磨、更耐冲刷、更可靠等特点；

Compared to the sandwich of the common butterfly valve made of rubber asbestos plate, graphite etc materials, that of the carbon fiber sandwich features more environmental protection, more wearable, more resisting to scouring and more reliable.

- 通过优化设计，使阀体具有高的强度，有效防止“负压”造成的阀体变形，保证阀门运行的安全和可靠性；

By means of optimized design, the valve is made with a high strength to effectively prevent the body deformation caused by "negative pressure" and ensure the valve to safely and reliably work.

- 填料函设有真空轴向密封装置，采用柔性石墨、成型石墨、PTFE等填料组合和活载式填料，使填料密封系统始终保持稳定。

The packing box is set with a vacuum axial sealing device and flexible graphite, formed graphite, PTFE etc. packing combination and live-loaded packing is used so as to have the sealing system of the packing kept stable all the time.

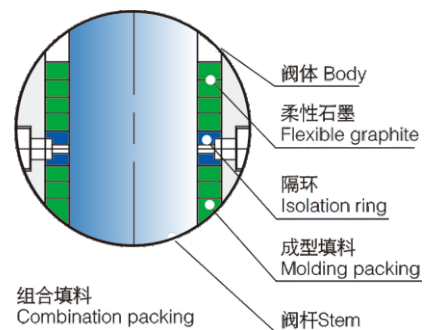
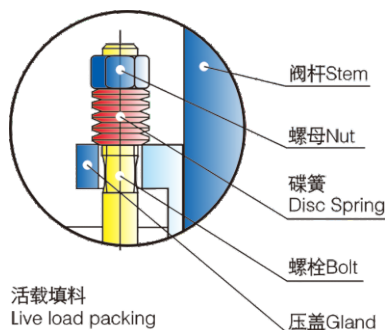
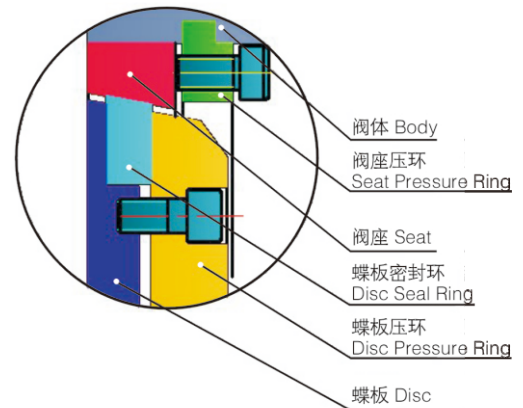

## 耐海水蝶阀 Resistant seawater butterfly valve

### 产品主要特点 Product main features

- 耐海水蝶阀采用浮动阀座橡胶密封的形式，可设计成双向密封结构。双偏心浮动阀座是在固定式阀座的基础上改进设计而成，其结构示意图如下：  
Seawater-proof butterfly valve uses the style of floating seat ring and rubber seal and can be designed in a bi-way sealing structure. The double-eccentric floating seat ring is made by improving the design of the fixed seat ring and the schematic diagram of its structure comes as below:
- 蝶板经过优化设计，能有效增加蝶阀过流面积，降低流体阻力，提高阀门流通能力；  
By means of optimized design, the butterfly plate can make the over-current area of the butterfly valve effectively increased and the fluid resistance reduced, thus enhancing the valve flowing capacity;
- 可以根据不同的工况，选用合适的蝶板密封圈，确保阀门在一个检修周期内不会产生内漏；  
It can be done to use a proper butterfly plate seal upon different working conditions so as to make sure of no internal leak of the valve within one overhaul period;
- 阀体、蝶板、压环等零部件为碳钢或者铸铁材料制成，有效降低制造成本，使阀门具有高的性价比。所有与介质接触部位喷涂陶瓷等耐磨耐腐蚀涂层，能增加阀门抗海水腐蚀和冲刷的能力；  
Valve body, butterfly plate, chunk ring etc. parts are made of carbon steel or cast iron, for the purpose to lower the manufacturing cost and to have the valve available with a high performance-price ratio. All the portions contacting with the medium are coated with ceramic etc. wearable and corrosion-proof coatings so as to enhance the valve capacity to resist seawater corrosion and erosion;
- 阀门轴套为双相不锈钢材料制成，且与阀体上的轴孔采用过盈配合，有效防止海水对阀体轴孔部位的腐蚀；  
The valve shaft sleeve is made of bi-phase stainless steel and uses an interference fit with the shaft hole on the body so as to effectively prevent the shaft hole against seawater corrosion;
- 阀门设有挡圈，能防止海水渗入阀杆与轴套之间，消除海水对阀杆及轴套的腐蚀。同时防止海水中的泥砂、沉积物、海生物等渗入阀杆与轴套的间隙内，造成阀杆与轴套咬合现象，有效提高了阀门的使用可靠性；  
The valve is set with a retainer ring, which can prevent seawater from penetrating in between both stem and shaft sleeve, eliminate the seawater corrosion to both and, meanwhile, prevent the muddy sand, deposit, sea creatures from penetrating into the interval between both, which will cause both to be occluded, to effectively enhance the reliability of the valve in its use;
- 阀座密封面堆焊双相不锈钢，提高阀门密封面的耐腐蚀能力和耐磨性；  
Bi-phase stainless steel is used for the surfacing welding on the sealing face of the seat ring, in order to enhance both anti-corrosion capacity and wearability of the said face;
- 采用活载组合式填料，即V型PTFE+V型EPDM填料，保证阀门在一个检修周期内不产生外漏。  
A live-load combined packing is used, e.g. type V PTFE + type V EPDM packing, in order to make sure of no external leak of the valve within one overhaul period;

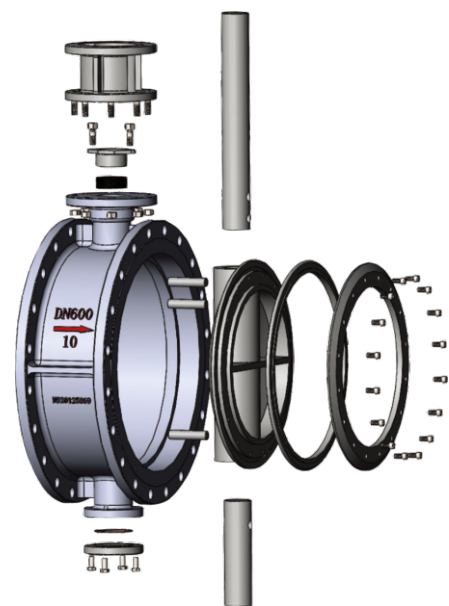
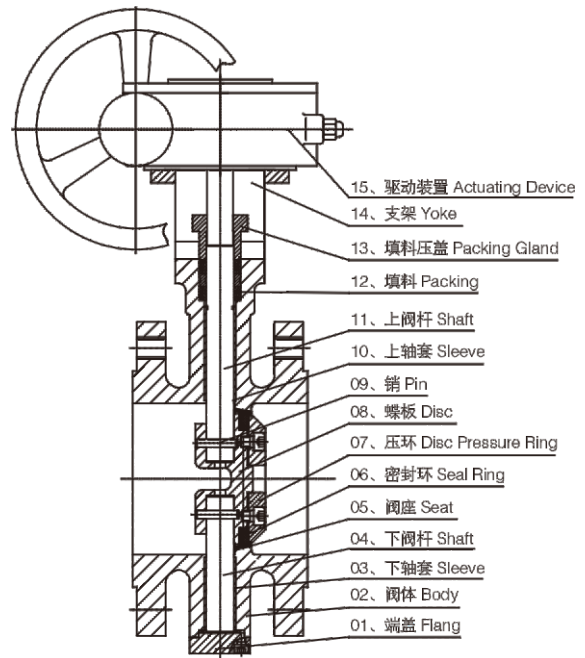

耐海水蝶阀的结构示意图



## 钛及钛合金蝶阀 Titanium and titanium alloy butterfly valve

### 产品主要特点 Product main features

- 钛及钛合金具有重量轻、强度高、耐腐蚀、耐高温等优越性能，钛及钛合金的一个最显著特点是，与氧的亲合力特别强，能在其表面形成一层致密的氧化膜，保护钛及钛合金不受介质的腐蚀，在大多数苛刻的工况下，这层氧化膜十分稳定，很难溶解，即使氧化膜遭到破坏，只要有充足的氧，就能很快重新生成。钛及钛合金阀门正是利用了钛材的这种特性，来适用于不同的有腐蚀工况。

Titanium and titanium alloy feature a light weight, high strength, anti-corrosion, temperature-proof etc. excellent performances and one most notable feature of them stays at the specially powerful appetency with oxygen, which makes their surfaces a layer of compact oxidized film to protect them against the medium corrosion. In most harsh working conditions, this layer of oxidized film is rather stable and very difficult to get dissolved and, even if destroyed, it can be reformed quickly, provided that oxygen is enough sufficient. The valves made of both just utilize this character to be made suitable for different corrosive working conditions.

- 我公司研制的含有专利技术的钛及钛合金蝶阀是众多的钛阀产品之一，与其它钛阀相比，具有以下特点：

**The titanium and titanium alloy butterfly valve covering patented technique developed by this Co. come as one of the lots titanium valves and, compared with other titanium valves, it holds the following features:**

- **重量轻、所需安装空间小 Light weight, small necessary installing space**  
钛及钛合金蝶阀重量更轻，同一规格钛及钛合金蝶阀的重量约为闸阀、截止阀、球阀的1/3，结构长度、安装高度等外形尺寸远小于其它钛阀；

The titanium and titanium alloy butterfly valve is very light in weight, to be about 1/3 that of the gate valve, stop valve and ball valve of the same norm, and its structural length and installing height etc. out-form sizes are far smaller than those of the other titanium valves;

- **卓越的耐腐蚀性能 Excellent anti-corrosion performance**

阀门所有与介质接触部分均为钛及钛合金材料加工而成，无其它任何非金属材料，使阀门具有极好的抗腐蚀能力。且在高流速、大流量的工况下，密封面更耐冲刷，从而避免了普通的钛蝶阀的种种弊端，使阀门具有更好的密封可靠性；

All the portions of the valve which will contact with the medium are made of titanium and titanium alloy, without any non-metal materials, so that the valve is made powerful to resist corrosion and its sealing face more resisting to erosion, avoiding various frauds with the common titanium butterfly valves and making it a better sealing reliability;

- **可靠的密封系统 Reliable sealing system**

阀门采用三偏心结构，即在普通金属硬密封蝶阀双偏心的基础上增加了一个角度偏心。这个角度偏心的主要作用是：使阀门在开启或关闭动作的过程中，密封环与阀座之间的任意一点都会迅速脱离或接触，做到密封副之间真正的“无摩擦”，极大地延长了阀门的使用寿命。

The valve uses a three-eccentric structure, that means to add one angle eccentric to the double eccentrics with the common metal hard seal butterfly valve. This eccentric acts mostly at: to have any point in between the seal ring and the seat ring quickly tripped or contacted, during the valve opening or closing process, to leave true "non-friction" between the seal pairs so as to greatly extend the valve life.

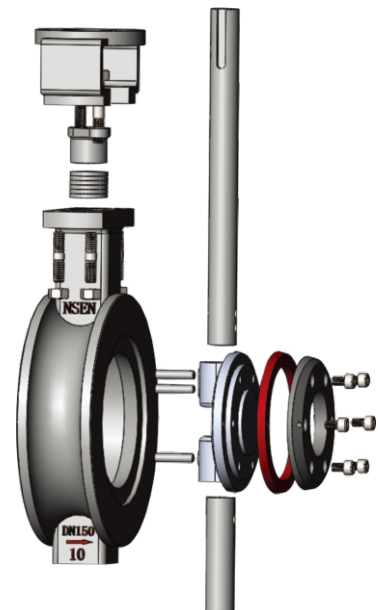
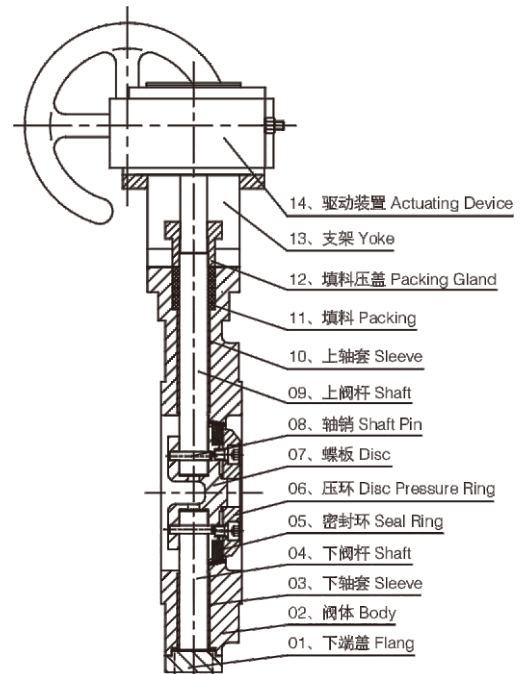

主要产品展示 Main product display

高性能金属密封蝶阀



双法兰式  
Double flanged type



对焊式  
Butt weld type



对夹式  
Wafer type



凸耳式  
Lug type

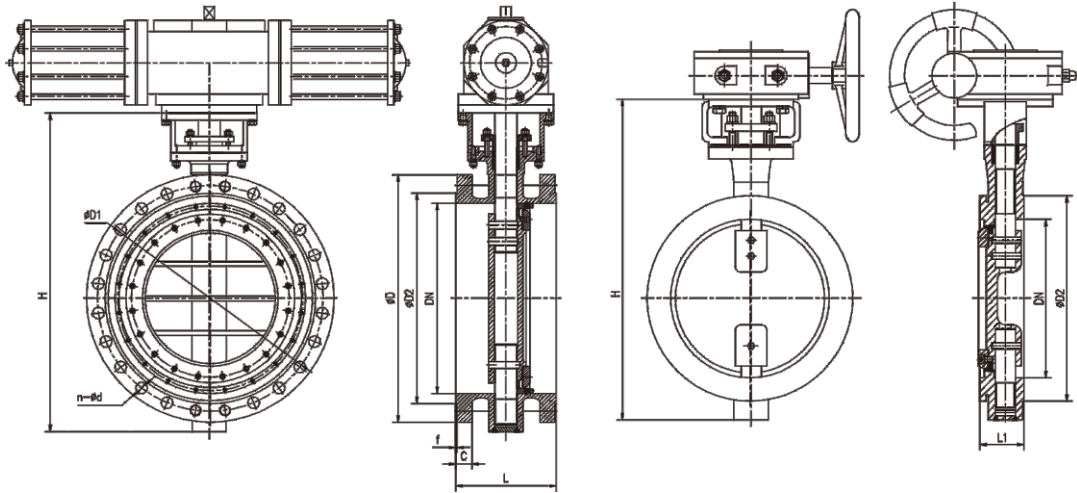

### 主要连接尺寸 Main connecting dimensions

公称通径 DN (mm)	PN 6										近似重量			
	L	L1	L2	L3	D	D1	D2	C	H	n-d	Kg(L)	Kg(L1)	Kg(L2)	Kg(L3)
80	114	49	180	49	190	150	124	18	310	4-18	20	11	17	13
100	127	56	190	56	210	170	144	18	325	4-18	23	13	19	16
125	140	64	200	64	240	200	174	18	360	8-18	28	16	25	20
150	140	70	210	70	265	225	199	20	395	8-18	33	21	28	24
200	152	71	230	71	320	280	254	22	480	8-18	48	28	49	36
250	165	76	250	76	375	335	309	24	550	12-18	54	45	95	52
300	178	83	270	83	440	395	363	24	610	12-22	80	61	130	79
350	190	92	290	92	490	445	413	24	710	12-22	103	82	160	107
400	216	102	310	102	540	495	463	24	755	16-22	145	122	216	150
450	222	114	330	114	595	550	518	24	835	16-22	193	150	248	183
500	229	127	350	127	645	600	568	26	900	20-22	258	205	380	254
600	267	154	390	154	755	705	667	30	1060	20-26	302	300	495	398
700	292	165	430	165	860	810	772	26	1170	24-26	385	465	595	576
800	318	190	470	190	975	920	878	26	1320	24-30	525	570	740	690
900	330	203	510	203	1075	1020	978	26	1440	24-30	723	760	1230	870
1000	410	216	550	216	1175	1120	1078	26	1640	28-30	990	975	1450	1180
1200	470	254	630	254	1405	1340	1295	28	1720	32-33	1455	1250	2180	1490
1400	530	390	710	390	1630	1560	1510	32	2055	36-36	1860	1780	2980	2050
1600	600	440	790	440	1830	1760	1710	34	2185	40-36	2180	1990		
1800	670	490	870	490	2045	1970	1918	36	2390	44-39	3950			
2000	760	540	950	540	2265	2180	2125	38	2620	48-42				
2200	800	590	1000	590	2475	2390	2335	42	2980	52-42				
2400	850	650	1100	650	2685	2600	2545	44	3150	56-42				
2600	900	700	1200	700	2905	2810	2750	46	3320	60-48				
2800	950	760	1300	760	3115	3020	2960	48	3550	64-48				
3000	1000	810	1400	810	3315	3220	3160	50	3770	68-48				



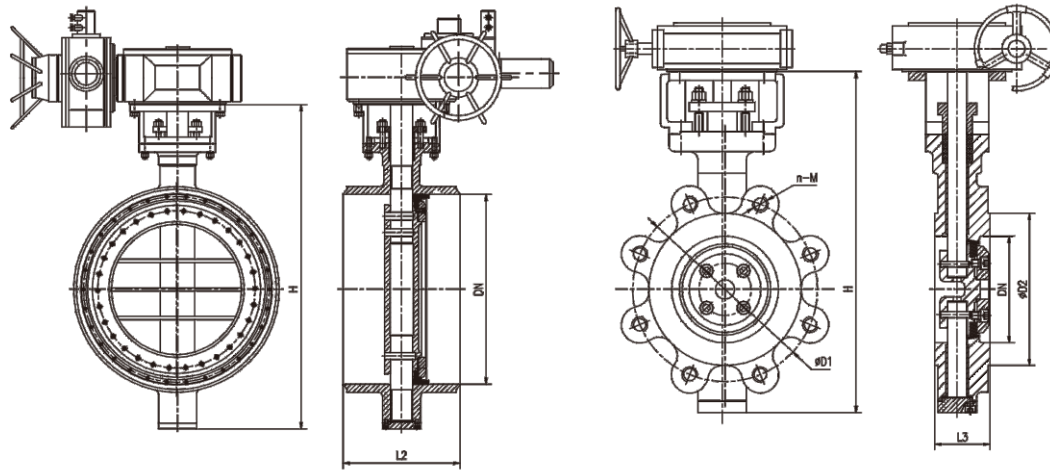

### 主要连接尺寸 Main connecting dimensions

公称通径 DN (mm)	PN 10										近似重量			
	L	L1	L2	L3	D	D1	D2	C	H	n-d	Kg (L)	Kg (L1)	Kg (L2)	Kg (L3)
80	114	49	180	49	200	160	132	20	310	8-18	22	11	17	13
100	127	56	190	56	220	180	156	22	325	8-18	24	13	19	19
125	140	64	200	64	250	210	184	22	360	8-18	30	16	25	23
150	140	70	210	70	285	240	211	24	395	8-22	38	21	28	29
200	152	71	230	71	340	295	266	24	480	8-22	56	28	49	51
250	165	76	250	76	395	350	319	26	550	12-22	70	45	95	69
300	178	83	270	83	445	400	370	26	610	12-22	92	61	130	109
350	190	92	290	92	505	460	429	26	710	16-22	115	82	178	143
400	216	102	310	102	565	515	480	26	755	16-26	169	122	238	195
450	222	114	330	114	615	565	530	28	835	20-26	220	150	275	265
500	229	127	350	127	670	620	582	28	900	20-26	265	205	423	335
600	267	154	390	154	780	725	682	34	1060	20-30	399	300	550	460
700	292	165	430	165	895	840	794	34	1170	24-30	489	465	665	740
800	318	190	470	190	1015	950	901	36	1320	24-33	652	570	815	920
900	330	203	510	203	1115	1050	1001	38	1440	28-33	880	760	1360	1180
1000	410	216	550	216	1230	1160	1112	38	1640	28-36	1215	975	1610	1320
1200	470	254	630	254	1455	1380	1328	44	1720	32-39	1790	1250	2415	1680
1400	530	390	710	390	1675	1590	1530	48	2010	36-42	2480	1780	3320	2160
1600	600	440	790	440	1915	1820	1750	52	2255	40-48	3220	2640		
1800	670	490	870	490	2115	2020	1950	56	2480	44-48	4350			
2000	760	540	950	540	2325	2230	2150	60	2660	48-48	5600			

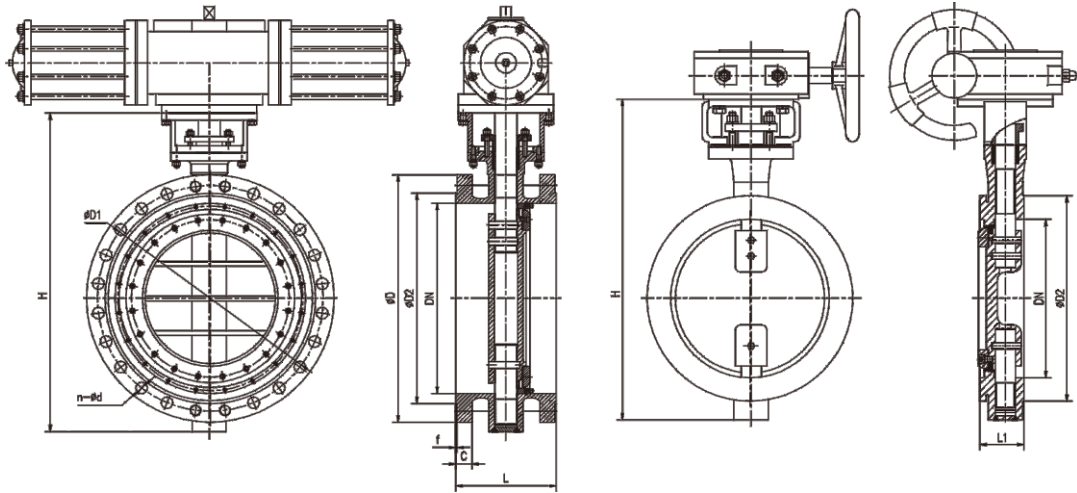

### 主要连接尺寸 Main connecting dimensions

公称通径 DN (mm)	PN 16										近似重量			
	L	L1	L2	L3	D	D1	D2	C	H	n-d	Kg(L)	Kg(L1)	Kg(L2)	Kg(L3)
80	114	49	180	49	200	160	132	20	310	8-18	22	11	17	13
100	127	56	190	56	220	180	156	22	325	8-18	24	13	19	19
125	140	64	200	64	250	210	184	22	360	8-18	30	16	25	23
150	140	70	210	70	285	240	211	24	395	8-22	38	21	28	29
200	152	71	230	71	340	295	266	24	480	12-22	56	40	49	51
250	165	76	250	76	405	355	319	26	550	12-26	80	50	95	69
300	178	83	270	83	460	410	370	28	610	12-26	108	75	130	109
350	190	92	290	92	520	470	429	30	710	16-26	140	102	178	143
400	216	102	310	102	580	525	480	32	755	16-30	206	145	238	195
450	222	114	330	114	640	585	548	40	835	20-30	262	190	275	265
500	229	127	350	127	715	650	609	44	900	20-33	318	255	423	335
600	267	154	390	154	840	770	720	54	1060	20-36	470	360	550	460
700	292	165	430	165	910	840	794	40	1170	24-36	553	470	665	740
800	318	190	470	190	1025	950	901	42	1320	24-39	688	655	815	920
900	330	203	510	203	1125	1050	1001	44	1440	28-39	999	897	1360	1180
1000	410	216	550	216	1255	1170	1112	46	1640	28-42	1435	1132	1610	1320
1200	470	254	630	254	1485	1390	1328	52	1850	32-48	2200	1400	2415	1680
1400	530	390	710	390	1685	1590	1530	58	2040	36-48	3200	1900	3320	2160
1600	600	440	790	440	1930	1820	1750	64	2280	40-55	6000	2900		
1800	670	490	870	490	2130	2020	1950	68	2495	44-55	6900	4000		
2000	760	540	950	540	2345	2230	2150	70	2685	48-60	9100	5300		

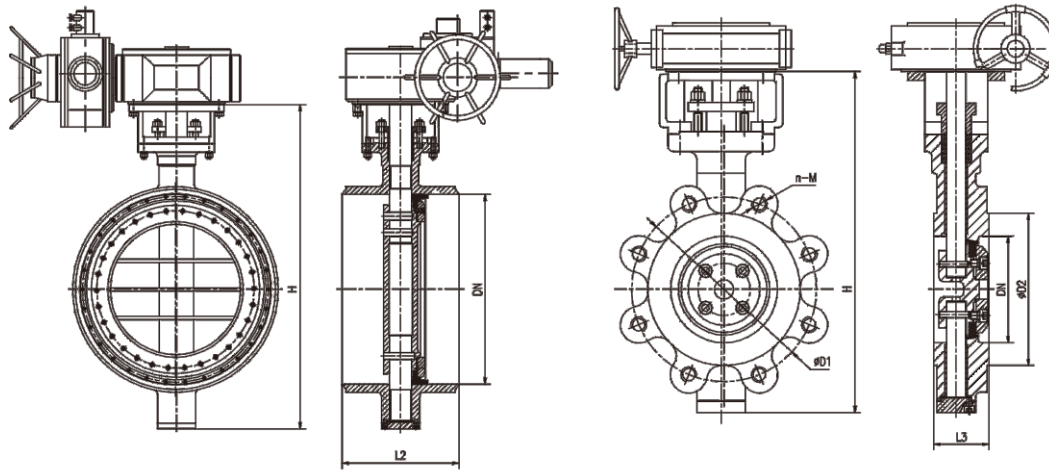

### 主要连接尺寸 Main connecting dimensions

公称通径 DN (mm)	PN 25										近似重量			
	L	L1	L2	L3	D	D1	D2	C	H	n-d	Kg (L)	Kg (L1)	Kg (L2)	Kg (L3)
80	114	49	180	49	200	160	132	24	310	8-18	23	11	17	13
100	127	56	190	56	235	190	156	24	325	8-22	25	13	19	19
125	140	64	200	64	270	220	184	26	360	8-26	34	16	25	23
150	140	70	210	70	300	250	211	28	395	8-26	42	21	28	29
200	152	71	230	71	360	310	274	30	480	12-26	58	40	49	51
250	165	76	250	76	425	370	330	32	550	12-30	90	50	95	69
300	178	83	270	83	485	430	389	34	610	16-30	120	75	130	109
350	190	92	290	92	555	490	448	38	710	16-33	170	102	178	143
400	216	102	310	102	620	550	503	40	755	16-36	235	145	238	195
450	222	114	330	114	670	600	548	46	835	20-36	285	190	275	265
500	229	127	350	127	730	660	609	48	900	20-36	385	255	423	335
600	267	154	390	154	845	770	720	58	1060	20-39	580	360	550	460
700	292	165	430	165	960	875	820	50	1170	24-42	705	470	665	740
800	318	190	470	190	1085	990	928	54	1320	24-48	970	655	815	920
900	330	203	510	203	1185	1090	1028	58	1440	28-48	1225	897	1360	1180
1000	410	216	550	216	1320	1210	1140	62	1640	28-55	1680	1132	1610	1320
1200	470	254	630	254	1530	1420	1350	70	1850	32-55	2450	1580	2415	1680
1400	530	390	710	390	1755	1640	1560	76	2040	36-60	3600	2100	3320	2160



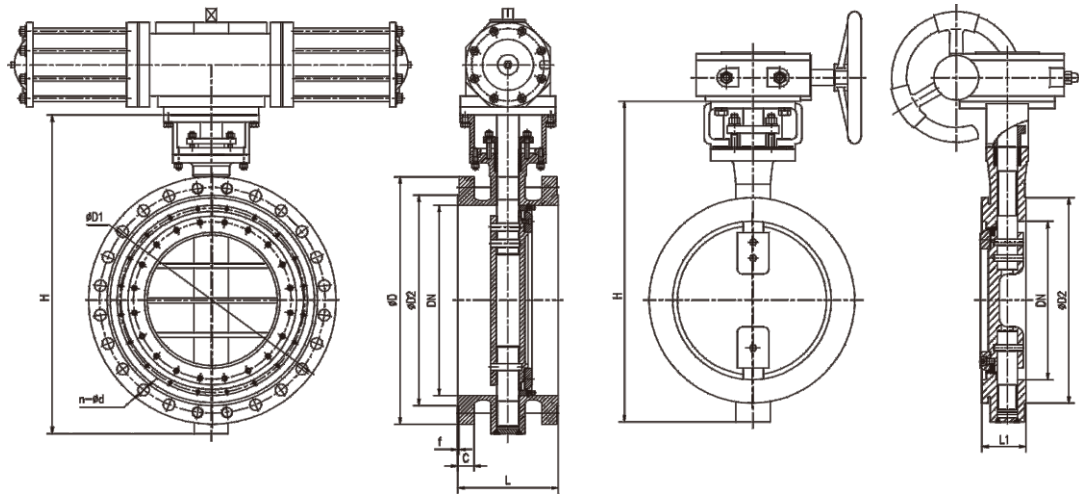

### 主要连接尺寸 Main connecting dimensions

公称通径 DN (mm)	PN 40									
	L	L1	L2	L3	D	D1	D2	C	H	n-d
80	114	49	180	49	200	160	132	24	310	8-18
100	127	56	190	56	235	190	156	24	325	8-22
125	140	64	200	64	270	220	184	26	360	8-26
150	140	70	210	70	300	250	211	28	395	8-26
200	230	71	230	71	375	320	284	34	515	12-30
250	250	76	250	76	450	385	345	38	675	12-33
300	270	83	270	83	515	450	409	42	805	16-33
350	290	92	290	92	580	510	465	46	850	16-36
400	310	102	310	102	660	585	535	50	895	16-39
450	330	152	330	152	685	610	560	57	960	20-39
500	350	159	350	159	755	670	615	57	1030	20-42
600	390	181	390	181	890	795	735	72	1180	20-48

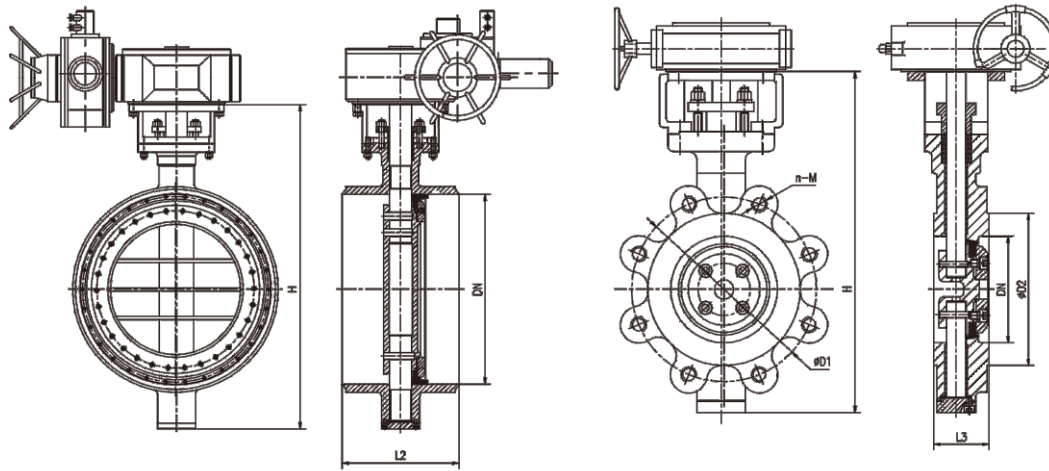

**主要连接尺寸 Main connecting dimensions**

公称通径 DN (mm)	PN 63									
	L	L1	L2	L3	D	D1	D2	C	H	n-d
80	180	64	180	64	215	170	132	28	310	8-22
100	190	64	190	64	250	200	156	30	325	8-26
125	200	70	200	70	295	240	184	34	360	8-30
150	210	76	210	76	345	280	211	36	430	8-33
200	230	89	230	89	415	345	284	42	535	12-36
250	250	114	250	114	470	400	345	46	695	12-36
300	270	114	270	114	530	460	409	52	805	16-36
350	290	127	290	127	600	525	465	56	880	16-39
400	310	140	310	140	670	585	535	60	930	16-42
450	330	160	330	160	715	630	560	64	990	20-42
500	350	170	350	170	800	705	615	68	1050	20-48
600	390	200	390	200	930	820	735	76	1230	20-56

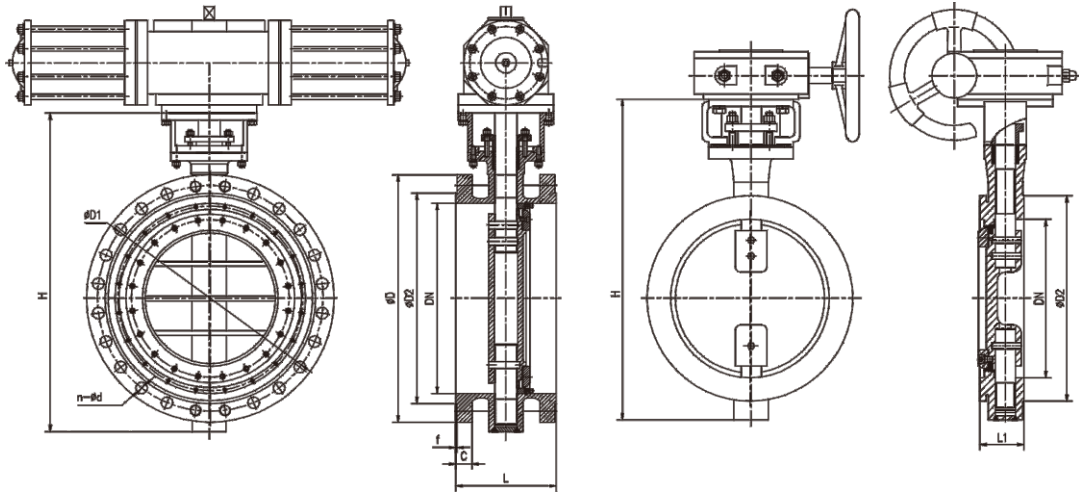

**主要连接尺寸 Main connecting dimensions**

公称通径 DN (mm)	PN 100									
	L	L1	L2	L3	D	D1	D2	C	H	n-d
150	210	76	210	76	355	290	211	44	425	12-33
200	230	89	230	89	430	360	284	52	640	12-36
250	250	114	250	114	505	430	345	60	745	12-39
300	270	114	270	114	585	500	409	68	820	16-42
350	290	127	290	127	655	560	465	74	935	16-48
400	310	140	310	140	715	620	535	82	975	16-48
450	330	160	330	160	770	675	560	89	1110	20-48
500	350	170	350	170	870	760	615	94	1215	20-56
600	390	200	390	200	990	875	735	102	1300	20-62

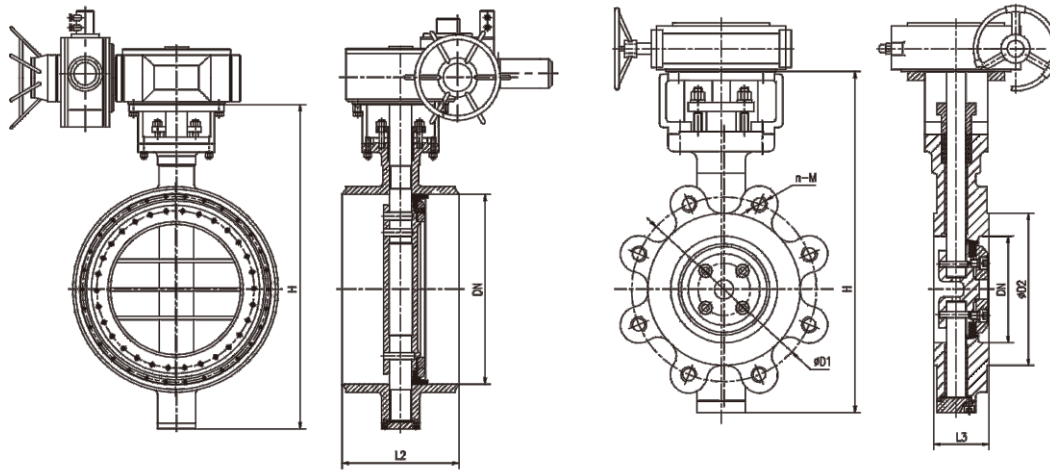

### 主要连接尺寸 Main connecting dimensions

公称通径DN		150Lb									
in	mm	L	L1	L2	L3	D	D1	D2	C	H	n-d
3	80	114	48	180	48	190	152.4	127	24.3	310	4-19
4	100	127	54	190	54	230	190.5	157	24.3	325	8-19
5	125	140	56	200	56	255	215.9	186	24.3	360	8-22
6	150	140	57	210	57	280	241.3	216	25.9	395	8-22
8	200	152	64	230	64	345	298.5	270	29	480	8-22
10	250	165	71	250	71	405	362.0	324	30.6	550	12-26
12	300	178	81	270	81	485	431.8	381	32.2	610	12-26
14	350	190	92	290	92	535	476.3	413	35.4	710	12-29
16	400	216	102	310	102	595	539.8	470	37	755	16-29
18	450	222	114	330	114	635	577.9	533	40.1	835	16-32
20	500	229	127	350	127	700	635.0	584	43.3	900	20-32
24	600	267	154	390	154	815	749.3	692	48.1	1060	20-35
28	700	292	165	430	165	925	863.6	800	71.9	1170	28-35
32	800	318	190	470	190	1060	977.9	914	81.4	1320	28-41
36	900	330	203	510	203	1170	1085.8	1022	90.9	1440	32-41
40	1000	410	216	550	216	1290	1200.2	1124	90.9	1640	36-41
48	1200	470	254	630	254	1510	1422.4	1359	108.4	1850	44-41
56	1400	530	390	710	390	1745	1651.0	1575	124.3	2040	48-48



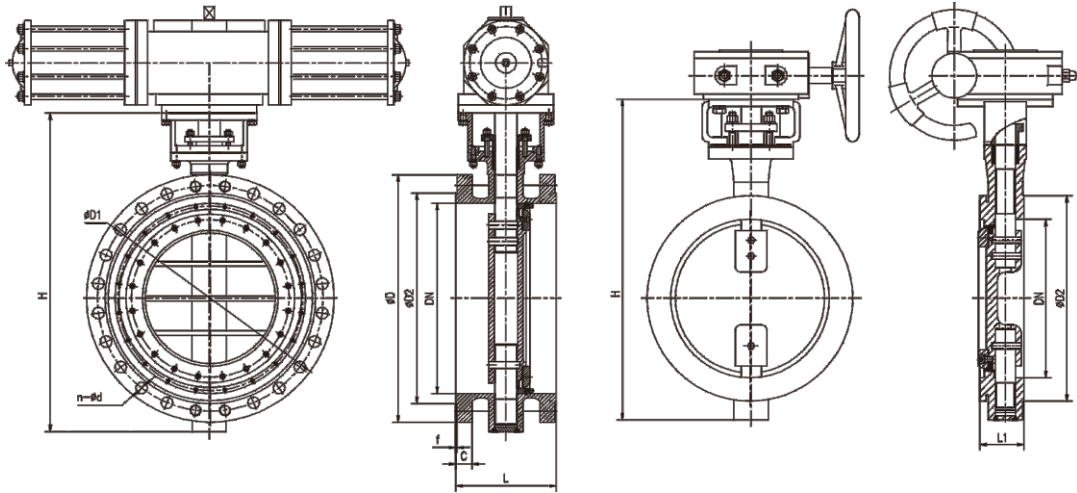

### 主要连接尺寸 Main connecting dimensions

公称通径DN		300Lb									
in	mm	L	L1	L2	L3	D	D1	D2	C	H	n-d
3	80	180	48	180	48	210	168.3	127	29	310	8-22
4	100	190	54	190	54	255	200.0	157	32.2	325	8-22
5	125	200	56	200	56	280	235.0	186	35.4	360	8-22
6	150	210	59	210	59	320	269.9	216	37	430	12-22
8	200	230	73	230	73	380	330.2	270	41.7	535	12-26
10	250	250	83	250	83	445	387.4	324	48.1	695	16-29
12	300	270	92	270	92	520	450.8	381	51.3	805	16-32
14	350	290	117	290	117	585	514.4	413	54.4	880	20-32
16	400	310	133	310	133	650	571.5	470	57.6	930	20-35
18	450	330	149	330	149	710	628.6	533	60.8	990	24-35
20	500	350	159	350	159	775	685.8	584	64	1050	24-35
24	600	390	181	390	181	915	812.8	692	70.3	1230	24-41

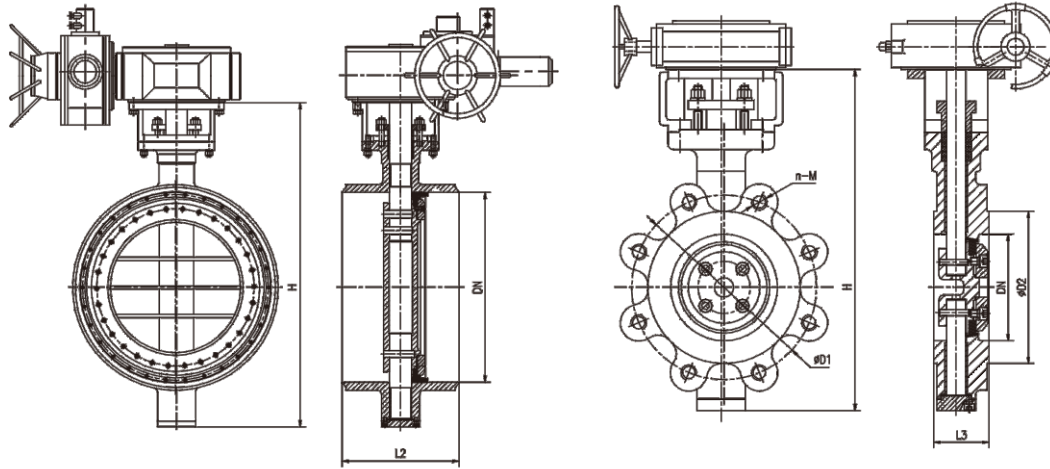

**主要连接尺寸 Main connecting dimensions**

公称通径DN		600Lb									
in	mm	L	L1	L2	L3	D	D1	D2	C	H	n-d
6	150	210	78	210	78	355	292.1	216	54.7	425	12-29
8	200	230	102	230	102	420	349.2	270	62.6	640	12-32
10	250	250	117	250	117	510	431.8	324	70.5	745	16-35
12	300	270	140	270	140	560	489.0	381	73.7	820	20-35
14	350	290	155	290	155	605	527.0	413	76.9	935	20-38
16	400	310	178	310	178	685	603.2	470	83.2	975	20-41
18	450	330	200	330	200	745	654.0	533	89.6	1110	20-45
20	500	350	216	350	216	815	723.9	584	95.9	1215	24-45
24	600	390	232	390	232	940	838.2	692	108.6	1300	24-51

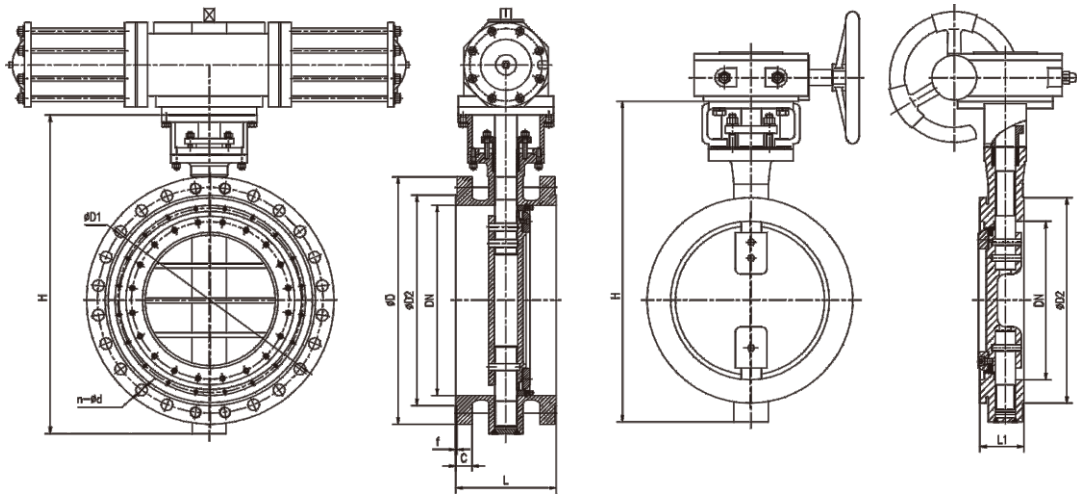

### 主要连接尺寸 Main connecting dimensions

公称通径DN		900Lb									
in	mm	L	L1	L2	L3	D	D1	D2	C	H	n-d
6	150	225	104	225	104	380	317.5	216	62.6	525	12-32
8	200	275	112	275	112	470	393.7	270	70.5	660	12-38
10	250	325	135	325	135	545	469.9	324	76.9	735	16-39
12	300	375	170	375	170	610	533.4	381	86.4	820	20-39
14	350	425	173	425	173	640	558.8	413	92.8	870	20-41
16	400	475	210	475	210	705	616	470	95.9	965	20-45
18	450	500	228	500	228	785	685.8	533	108.6	1050	20-51
20	500	575	250	575	250	855	749.3	584	115	1175	20-54
24	600	675	275	675	275	1040	901.7	692	146.7	1330	20-67

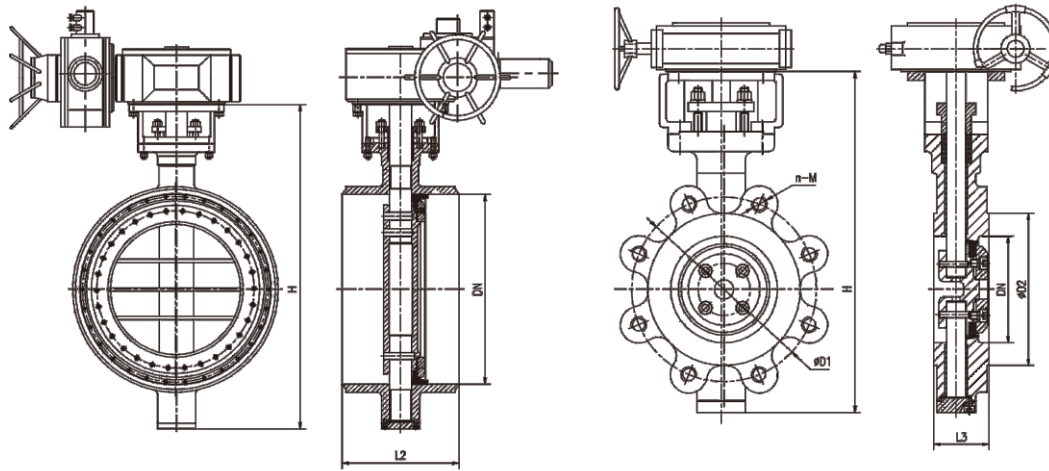

**主要连接尺寸 Main connecting dimensions**

公称通径DN		1500Lb									
in	mm	L	L1	L2	L3	D	D1	D2	C	H	n-d
6	150	350	160	350	160	395	317.5	216	89.6	550	12-38
8	200	400	180	400	180	485	393.7	270	99.1	690	12-45
10	250	450	200	450	200	585	482.6	324	115	780	12-51
12	300	500	230	500	230	675	571.5	381	130.9	905	16-54
14	350	550	250	550	250	750	635	413	140.4	990	16-60
16	400	600	265	600	265	825	704.8	470	153.1	1085	16-67
18	450	650	300	650	300	915	774.7	533	169	1180	16-73
20	500	700	340	700	340	985	831.8	584	184.8	1290	16-80
24	600	800	400	800	400	1170	990.6	692	210.2	1450	16-92



**Cv值**

**150Lb**

Size		5°	10°	15°	20°	25°	30°	35°	40°	45°	50°	55°	60°	65°	70°	75°	80°	85°	90°
mm	in																		
80	3	1	6	14	23	31	39	47	54	62	71	82	96	112	128	143	156	163	163
100	4	2	12	26	42	57	72	85	98	113	130	150	176	205	234	262	285	299	302
150	6	16	31	45	59	76	101	134	178	233	297	369	448	531	616	698	758	796	796
200	8	30	57	82	108	140	185	246	327	427	544	676	821	974	1130	1280	1390	1460	1460
250	10	52	99	142	187	242	320	426	566	739	942	1170	1420	1690	1960	2220	2410	2530	2530
300	12	78	147	212	279	362	478	636	846	1100	1410	1750	2120	2520	2920	3310	3600	3780	3780
350	14	106	201	289	380	493	651	866	1150	1500	1920	2380	2890	3430	3980	4510	4890	5140	5140
400	16	165	313	451	594	769	1020	1350	1800	2350	2990	3720	4510	5350	6210	7040	7640	8020	8020
450	18	217	413	594	782	1010	1340	1780	2370	3090	3940	4890	5940	7050	8180	9270	10100	10600	10600
500	20	268	509	733	965	1250	1650	2200	2920	3820	4860	6040	7340	8710	10100	11400	12400	13000	13000
600	24	386	734	1060	1390	1800	2380	3170	4210	5500	7000	8700	10600	12500	14500	16500	17900	18800	18800
700	28	559	1060	1530	2010	2610	3450	4590	6100	7960	10100	12600	15300	18200	21000	23900	25900	27200	27200
750	30	630	1200	1720	2270	2940	3880	5160	6870	8960	11400	14200	17200	20400	23700	28900	29200	30700	30700
800	32	719	1370	1970	2590	3360	4440	5900	7840	10200	13000	16200	19700	23300	27100	30700	33300	35000	35000
900	36	884	1680	2420	3180	4210	5450	7250	9630	12600	16000	19900	24200	28700	33300	37700	40900	43000	43000
1000	40	1170	2220	3190	4210	5450	7210	9580	12700	16600	21200	26300	31900	37900	44000	49800	54100	56900	56900
1050	42	1230	2340	3370	4440	5760	7610	10100	13400	17600	22400	27800	33700	40000	46500	52600	57100	60000	60000
1200	48	1640	3120	4490	5920	7670	10100	13500	17900	23400	29800	37000	45000	53400	61900	70100	76100	80000	80000

**300Lb**

Size		5°	10°	15°	20°	25°	30°	35°	40°	45°	50°	55°	60°	65°	70°	75°	80°	85°	90°
mm	in																		
80	3	1	6	14	23	31	39	47	54	62	71	82	96	112	128	143	156	163	165
100	4	2	12	26	42	57	72	85	98	113	130	150	176	205	234	262	285	299	302
150	6	6	25	41	54	69	91	121	162	212	268	334	407	482	559	634	689	725	725
200	8	11	45	74	98	126	166	222	298	389	492	613	746	884	1030	1160	1260	1330	1330
250	10	19	82	135	178	229	301	402	540	705	891	1110	1350	1600	1860	2110	2290	2410	2410
300	12	29	122	202	266	342	450	601	807	1050	1330	1660	2020	2400	2780	3150	3420	3600	3600
350	14	39	167	274	363	466	613	818	1100	1430	1810	2260	2750	3260	3780	4290	4660	4900	4900
400	16	58	248	408	539	692	910	1220	1630	2130	2690	3360	4090	4840	5610	6370	6920	7280	7280
450	18	77	326	537	710	911	1200	1600	2150	2810	3550	4420	5380	6380	7400	8390	9110	9590	9590
500	20	95	403	663	876	1130	1480	1980	2650	3460	4380	5460	6640	7880	9130	10400	11300	11800	11800
600	24	136	580	955	1260	1620	2130	2850	3820	4990	6310	7860	9570	11300	13100	14900	16200	17100	17100
700	28	199	844	1390	1840	2360	3100	4150	5560	7260	9190	11400	13900	16500	19100	21700	23600	24800	24800
750	30	232	986	1620	2150	2750	3620	4840	6490	8480	10700	13400	16300	19300	22400	25400	27500	29000	29000
800	32	261	1110	1830	2420	3100	4080	5450	7310	9550	12100	15000	18300	21700	25200	28600	31000	32600	32600
900	36	332	1410	2320	3070	3940	5190	6930	9300	12100	15400	19100	23300	27600	32000	36300	39400	41500	41500
1000	40	399	1700	2790	3690	4740	6230	8330	11200	14600	18400	23000	28000	33200	38400	43600	47400	49900	49900
1050	42	457	1940	3200	4230	5430	7140	9540	12800	16700	21100	26300	32000	38000	44000	50000	54200	57100	57100
1200	48	480	2040	3360	4440	5700	7500	10000	13400	17500	22200	27700	33700	39900	46300	52500	57000	60000	60000

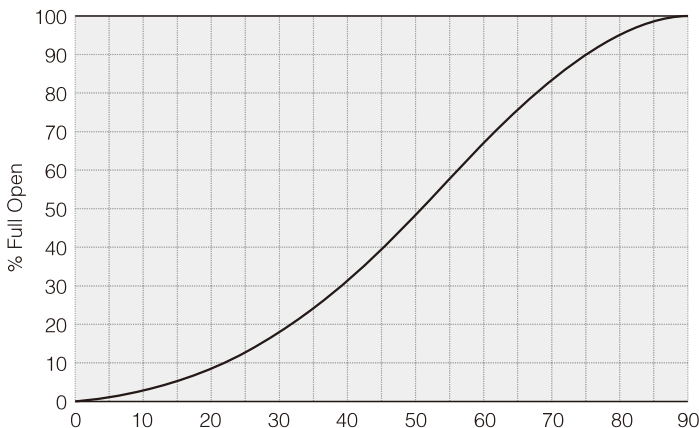

**Typical Flow Characteristics**

For control applications a wide variety of actuators and accessories can be provided. At moderate pressure drop conditions, turndown approaching 100 to 1 can be achieved because of the camming action of the disc opening. The disc lifts off the seat very quickly and an equal percentage control curve is produced between 15° to 75°

## Materials ASTM A216-WCB.A217-C5 A351-CF8

Pressure-temperature  
Ratings to ASME B16.34

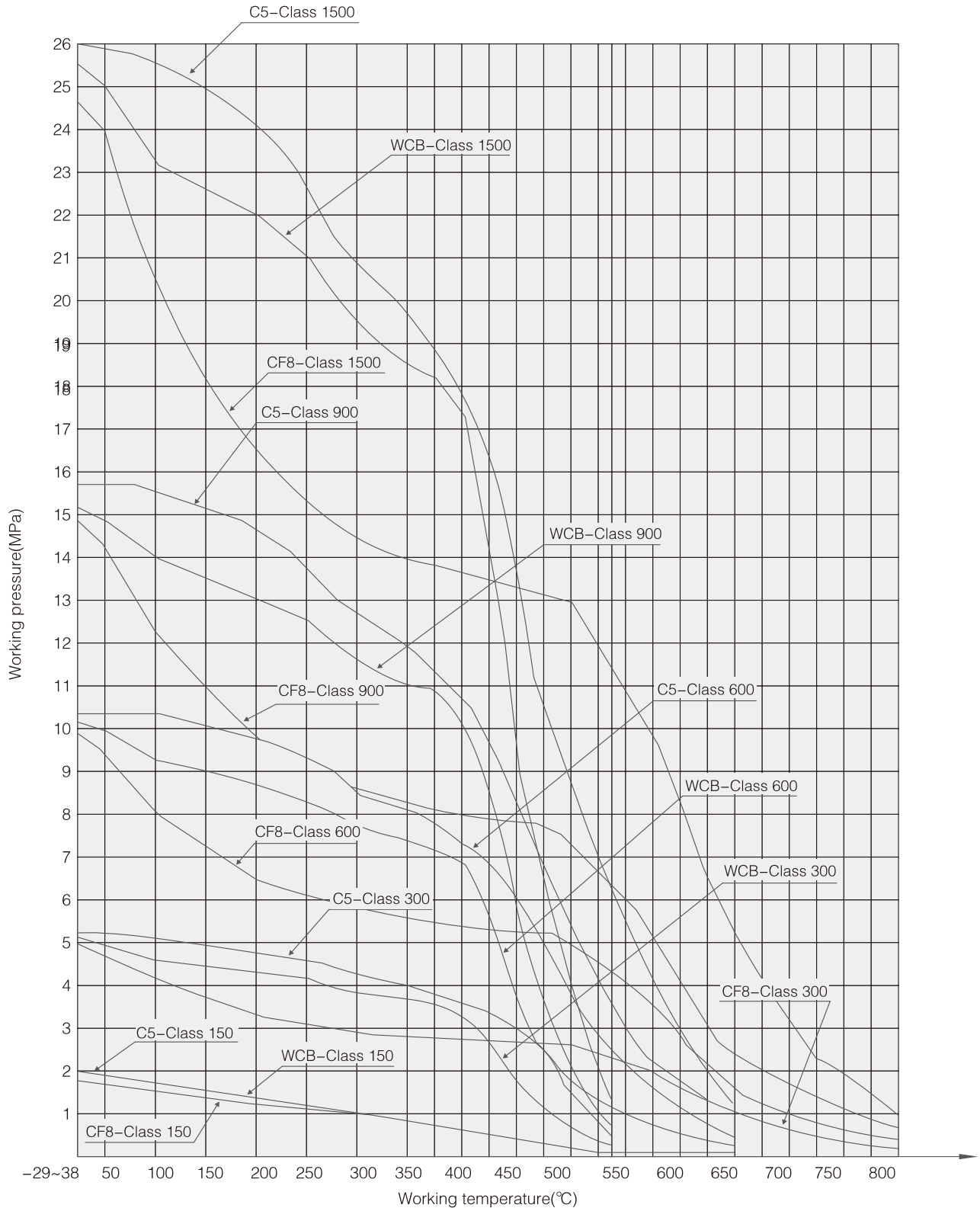

高性能金属密封蝶阀

**材质表 Materials list**

Astm standard	Chemical compositions [%]										Mechanical properties				Hardness Brinell max
	C max	Mn max	P max	S max	Si max	Cr	Mo	Ni	Cu max	V	Tensile [MPa]min	Yield [MPa]min	Elongation [%]min	Reduction [%]min	
A216 WCB	0.30	1.00	0.040	0.045	0.60	≤0.50	≤0.25	≤0.50	0.30	0.03	485	250	22	35	
A216 WCC	0.25	1.20	0.040	0.045	0.60	≤0.50	≤0.25	≤0.50	0.30	0.03	485	275	22	35	
A352 LC3	0.15	0.50-0.80	0.040	0.045	0.60			3.00-4.00			485-655	275	24	35	
A217 WC6	0.05-0.20	0.50-0.80	0.040	0.045	0.60	1.00-1.50	0.45-0.65	0.50	0.50		485-655	275	20	35	
A217 WC9	0.05-0.18	0.40-0.70	0.040	0.045	0.60	2.00-2.75	0.90-1.20	0.50	0.50		485-655	275	20	35	
A217 C5	0.20	0.40-0.70	0.040	0.045	0.75	4.00-6.50	0.45-0.65	0.50	0.50		620-795	415	18	35	
A351 CF3	0.03	1.50	0.040	0.040	2.00	17.0-21.0	≤0.50	8.0-12.0			485	205	35		
A351 CF3M	0.03	1.50	0.040	0.040	1.50	17.0-21.0	2.0-3.0	9.0-13.0			485	205	30		
A351 CF8	0.08	1.50	0.040	0.040	2.00	18.0-21.0	≤0.50	8.0-11.0			485	205	35		
A351 CF8M	0.08	1.50	0.040	0.040	1.50	18.0-21.0	2.0-3.0	9.0-12.0			485	205	30		
A351 CF8C	0.08	1.50	0.040	0.040	2.00	18.0-21.0	≤0.50	9.0-12.0			485	205	30		
A351 CN7M	0.07	1.50	0.040	0.040	1.50	19.0-22.0	2.0-3.0	27.5-30.5			450	170	35		
A105	0.35	0.60-1.05	0.035	0.040	0.10-0.35	≤0.30	≤0.12	≤0.40	0.40	0.08	485	250	22	30	187
A182 F6A	0.15	1.00	0.040	0.030	1.00	11.5-13.5		≤0.50			485	275	18	35	143-207
A182 F304	0.08	2.00	0.045	0.030	1.00	18.0-20.0		8.0-11.0			515	205	30	50	
A182 F304L	0.03	2.00	0.045	0.030	1.00	18.0-20.0		8.0-13.0			485	170	30	50	
A182 F316	0.08	2.00	0.045	0.030	1.00	16.0-18.0	2.0-3.0	10.0-14.0			515	205	30	50	
A182 F316L	0.03	2.00	0.045	0.030	1.00	16.0-18.0	2.0-3.0	10.0-15.0			485	170	30	50	
A182 F321	0.08	2.00	0.045	0.030	1.00	17.0-19.0		9.0-12.0			515	205	30	50	
A182 F11	0.10-0.20	0.30-0.80	0.040	0.040	0.50-1.00	1.0-1.5	0.44-0.65				515	310	20	30	156-207
A182 F22	0.05-0.15	0.30-0.60	0.040	0.040	0.50	2.0-2.5	0.87-1.13				515	310	20	30	156-207
A182 F5	0.15	0.30-0.60	0.030	0.030	0.50	4.0-6.0	0.44-0.65	≤0.50			485	275	20	35	143-217
A350 LF2	0.30	0.60-1.35	0.035	0.040	0.15-0.30	≤0.30	≤0.12	≤0.40	0.40	0.08	485-655	250	22	30	
A276 410	0.08-0.15	1.00	0.040	0.030	1.00	11.5-13.5					480	275	16	45	
A276 420	0.15	1.00	0.040	0.030	1.00	12.0-14.0									255
A276 321	0.08	2.00	0.045	0.030	1.00	17.0-19.0		9.0-12.0			515	205	30	40	
A320 L7	0.38-0.48	0.75-1.00	0.035	0.040	0.15-0.35	0.80-1.10	0.15-0.25				860	725	16	50	321
A320 L7M	0.38-0.48	0.75-1.00	0.035	0.040	0.15-0.35	0.80-1.10	0.15-0.25				690	550	18	50	235
A193 B7	0.37-0.49	0.65-1.10	0.035	0.040	0.15-0.35	0.75-1.20	0.15-0.25				860	720	16	50	321
A193 B7M	0.37-0.49	0.65-1.10	0.035	0.040	0.15-0.35	0.75-1.20	0.15-0.25				690	550	18	50	235
A193 B16	0.36-0.47	0.45-0.70	0.035	0.040	0.15-0.35	0.80-1.15	0.50-0.65			0.25-0.35	860	725	18	50	321
A193 B8	0.08	2.00	0.045	0.030	1.00	18.0-20.0		8.0-11.0			515	205	30	50	223
A193 B8M	0.08	2.00	0.045	0.030	1.00	16.0-18.0	2.00-3.00	10.0-14.0			515	205	30	50	223
A194 2H	≥0.40	1.00	0.040	0.050	0.40										
A194 7	0.37-0.49	0.65-1.10	0.035	0.040	0.15-0.35	0.75-1.20	0.15-0.25								248-327
A194 8	0.08	2.00	0.045	0.030	1.00	18.0-20.0		8.0-11.0							126-300
A194 8M	0.08	2.00	0.045	0.030	1.00	16.0-18.0	2.00-3.00	10.0-14.0							126-300

## 阀门故障分析 Analysis on valve failure

对于用户来说，实际使用工况与阀门规定的适用范围一致，以及操作正确与认真维护保养时，直接关系到阀门故障的避免与使用寿命的延长。It is directly related to avoidance of any valve failure and extension of the valve life for the users to let the working conditions identical to those set in the applicable range of the valve, the operations correctly done and the maintenance carefully carried out.

常见事故详见下表：

See the table below for the common failures:

故障Failure	分析产生原因Cause analysis	消除故障方法Method of settlement
填料处的外漏 leaking outward at the packing	1、填料超期使用、已老化。 The packing is in exceeded use and gets aged. 2、操作时用力过大。 Excessive force is used in operation. 3、活节螺栓没有拧紧。 The eyelet bolt is not tightened.	1、应及时更换老化、损坏的填料并逐圈安放接头呈30°-50°。 Replace the aged and injured packing in time, place the connectors turn by turn and let them 30°-50° presented. 2、应以正常力均匀操作、不许加套管或用其它办法。 Use normal even operation and do not use bushing or any other ways. 3、均匀拧紧压住填料用螺栓。 Evenly tighten the bolts used to tightly press the packing.
密封面泄漏 leaking at the sealing surface	1、阀门安装方向和介质流向不符。 The valve installation direction does not conform to the medium flowing direction. 2、关闭不到位。 Closing is not in place. 3、久闭的阀门在密封面上积垢。 The sealing surface of a long time closed valve gets scaled. 4、密封面上损伤严重。 The sealing surface gets seriously injured.	1、注意安装检查。 Pay attention to the installation checkup. 2、关严到位。 Make closing in place. 3、将阀门开一条缝，让高速流体冲掉密封上脏物。 Let the valve in crack to have the dirty on the seal flushed out by the high speed fluid. 4、重新研磨，加厚调节垫片补偿。 Regrind and thicken the adjusting gasket compensation.
法兰连接处泄漏 leaking at the flange connection	1、螺栓拧紧力不均。 The bolts are unevenly tightened. 2、垫片老化损伤。 The gasket gets aged and injured. 3、垫片选用材质与工况介质要求不符。 The gasket material does not conform to the required working condition medium.	1、重新均匀拧紧螺栓。Evenly tighten the bolts again. 2、及时更换。Replace it in time. 3、按工况要求正确选用垫片材料和形式，必要时请与厂家联系请求帮助选材选型，订货时要详细说明要求。 Use correct gasket material and type in accordance with the working condition requirement and, when necessary, ask the manufacturer for help and note the detailed requirement at order.
手柄、手轮的损坏 damage of handle and handwheel	1、使用不正确。 Incorrect use. 2、紧固件松动。 The fastener gets loosened. 3、手柄、手轮与阀杆连接损伤。 Damaged connection between the handle, handwheel and stem.	1、禁止使用管子钳、长杠杆、撞击工具等。 Never use grip wrench, long lever, impacting tools. 2、随时修配。 Repair and fit it in time. 3、随时修复。 Repair it in time.
蜗轮、蜗杆传动卡咬 seizure between worm and gear	1、不清洁嵌入脏物，影响润滑。 Dirt gets inlaid to affect the lubrication. 2、操作不善。 Improper operation.	1、请保持清洁，定期加油。 Keep it clean and oil it in a fixed period of time. 2、若操作是发现卡咬，阻力很大时，不能继续操作，否则损坏加剧。 In case of seizure and a heavy resistance during operation, do not go on operation, or damage would get increased.
电动安装故障 Electric installation failure	1、润滑不良，Bad lubrication。 阀门内有异物卡住造成转矩过大损坏。 Foreign matters are available inside of the valve to make the torque exceeded and injured. 2、电动故障。Electric failure.	1、应加油，操持清洁，使油管良好，填料压紧应适度，应及时排除阀内异物。 Do oiling and keep clean to make the oil tube in good condition, let the packing properly pressed and the foreign matters inside of the valve out in time. 2、电机工作时间不超过15分钟，电源应正常，应避免电机受潮，the power supply shall be kept normal.





## Chemsun Europe GmbH

Schumannstr.156, 63069 Offenbach am Main, Germany  
Tel.: +49 (0) 69 7598 636 0  
Fax: +49 (0) 69 7598 636 88  
Email: sales@chemsun.de  
Web: www.chemsun.de

## 德国凯姆斯北京办事处

地址：北京市大兴区长子营长恒路20号院11号楼  
电话：+86 10 56370175-828  
+86 10 56370179-828  
传真：+86 10 56370179  
邮箱：ljz19780506@126.com

地区或项目经销商：