

# Full Port Ball Valves



<b>Flanges Connection</b>	<b>2-Piece Type CSFB-2M</b>	DN15 to 200 (NPS 1/2 to 8)
<b>Thread Connection</b>	<b>1-Piece Type CSFB-1M</b>	DN8 to 80 (NPS 1/4 to 3)
<b>Thread Connection</b>	<b>3-Piece Type CSFB-3M</b>	DN8 to 100 (NPS 1/4 to 4)

DIN / ANSI version

**Pressure rating** PN16 / 40 / 63 (ANSI 150/300/600 Lb)  
**Temperatures** -20 to +200 °C

## Application

Full port ball valves for process engineering and industrial applications and Utility lines (water, air)

## Structure (connection mode) classification

- **Flanges**  
2-Piece Type CSFB-2M DN15 to 200 (NPS 1/2 to 8)
- **BSP & NPT Thread**  
1-Piece Type CSFB-1M DN08 to 80 (NPS 1/4 to 3)
- **BW & BSP Thread**  
3-Piece Type CSFB-3M DN08 to 100 (NPS 1/4 to 4)

## Design

- Standard
- With live-loaded sealing system
- Fire-safe version with test certificate according to British
- Standard B.S. 6755 Part 2

## Features

- Valve body made of stainless steel 1.4408/A351 CF8M or WN1.4308/A351CF8 or WN1.0619/A216WCC
- Seat ring live-loaded on one side or with floating ball.
- Exchangeable bore seal
- On/off service with leakage rate A according to DIN EN 12266-1, bubble-tight version
- Shaft sealed by a self-adjusting PTFE V-ring packing, loaded by spring washers, requiring no maintenance.
- Blowout-proof shaft made of 1.4462, TA Luft.
- DIN face-to-face dimensions according to EN 558 or DIN EN 1092
- ANSI face-to-face dimensions according to ASME B16.10-2000
- Connecting flange for actuators according to DIN ISO 5211
- Double body seal system



Fig.1 Type CSFB-2M 2-Piece Ball Valve [Flange]



Fig.2 Type CSFB-1M 1-Piece Ball Valve



Fig.3 Type CSFB-3M 3-Piece Ball Valve

## Flanges connection mode

### 2-Piece Ball Valve Type CSFB-2M Series

DN15 to 200 (NPS 1/2 to 8)

DIN / ANSI version

#### 2-Piece Components

1. Main body
2. Side body
3. ball
4. Ball
5. Shaft
6. Packing
7. Bearing bushing
8. Bearing bushing
9. Set of set ring
10. PTFE ring
- 10a. Graphite ring
11. Set of spring washers
12. V-ring packing
13. Spring washer
14. Screw
15. Screw
16. Stud bolt
17. Nut
18. Graphite ring
19. Graphite ring
20. Bushing
21. Lever

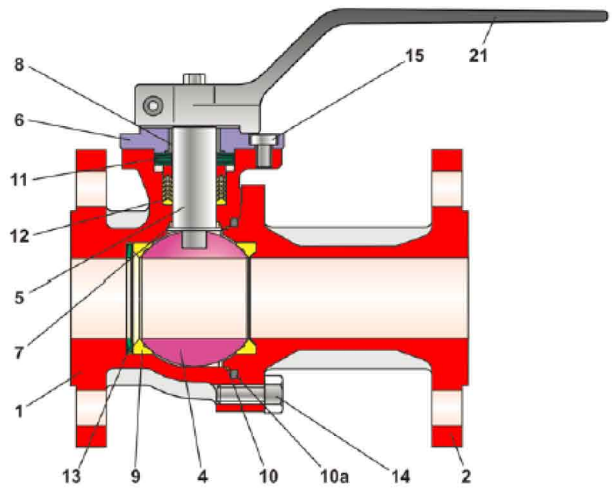
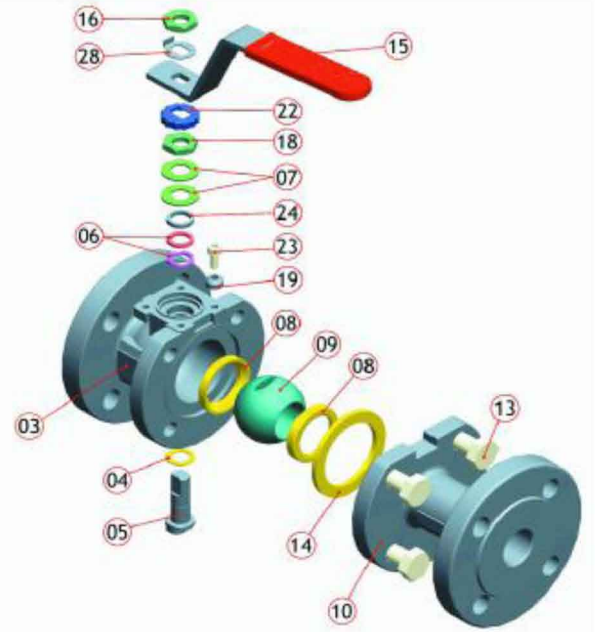

Fig.4: Type CSFB-2M Ball Components

#### Floating ball and live-loaded sealing system

- Maintenance-free and self-adjusting.
- Highest level of sealing, even under extreme pressure and temperature fluctuations
- Longer service life.

#### Live-loaded sealing system

- Two active seat rings.
- Reduced increase in torque at increasing temperatures.
- As a result, smaller actuators are required for automation.

**All in all: extremely economic!**

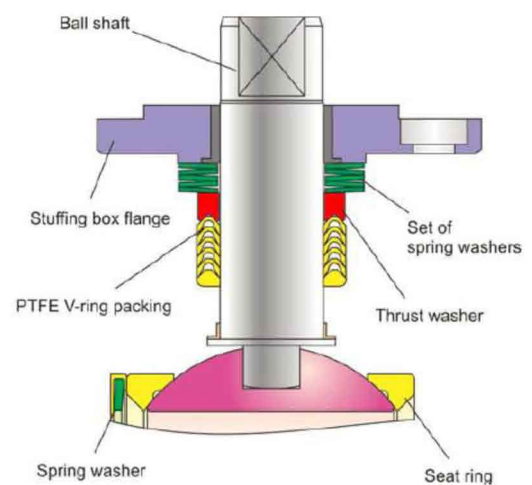
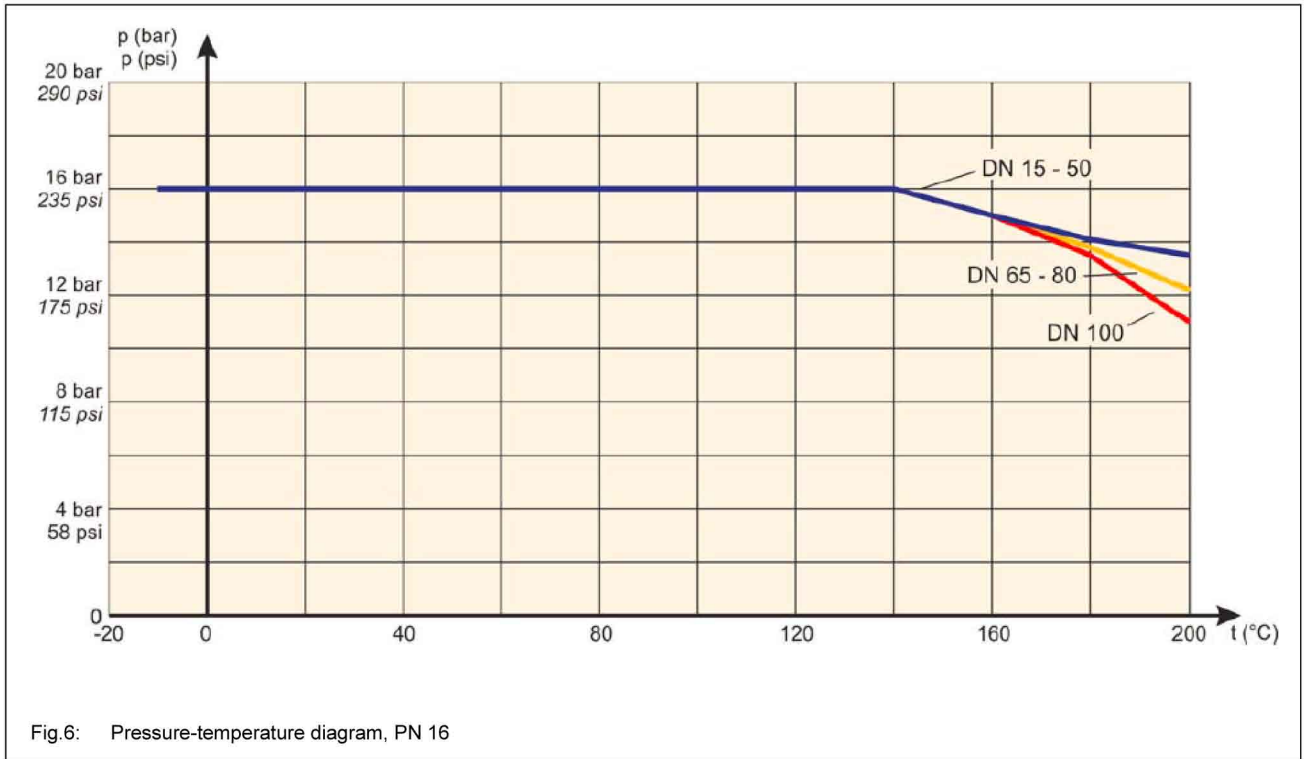

Fig.5: Live-load sealing system

## Pressure-temperature diagrams for DIN version

The operating range is determined by the pressure-temperature diagram.  
Process data and medium may influence the values in the diagram.

### Pressure-temperature diagram DN15 to 200 , PN 16



### Pressure-temperature diagram, DN15 to 100 , PN 40

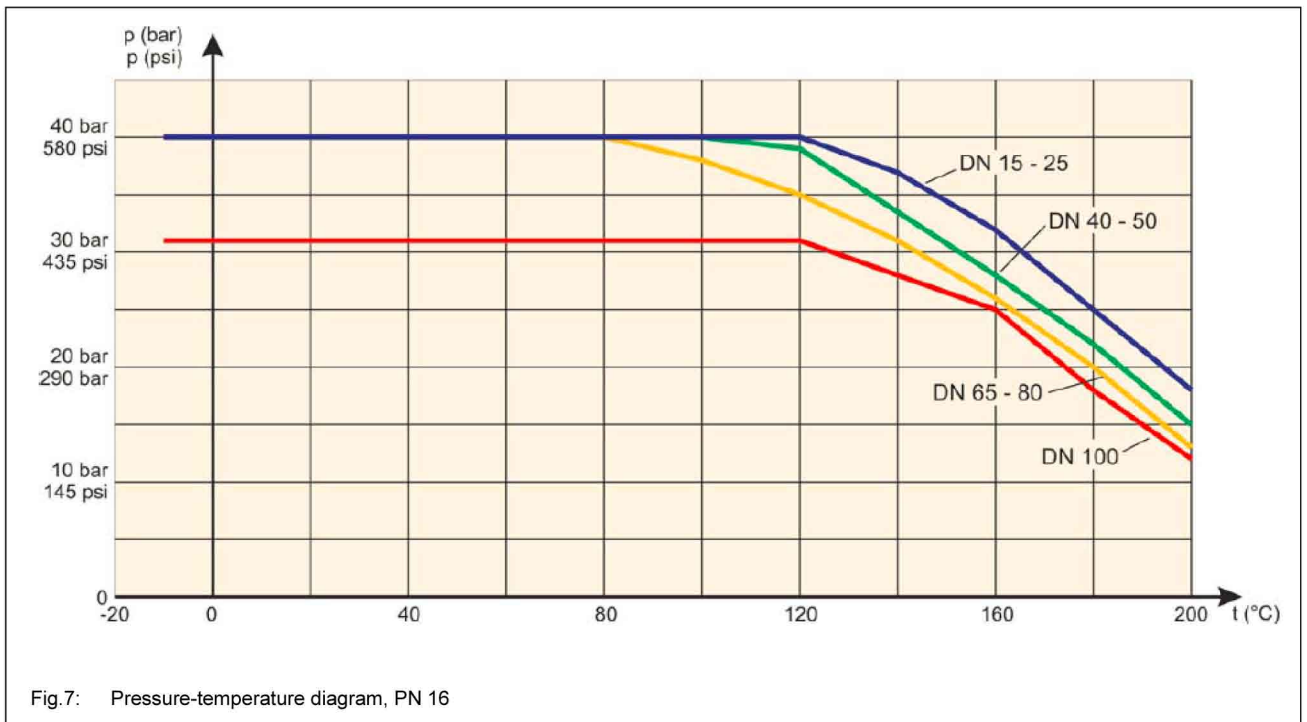

## Pressure-temperature diagrams for ANSI version

The operating range is determined by the pressure-temperature diagram. Process data and medium may influence the values in the diagram.

### Pressure-temperature diagram NPS 1/2 to 8" , Class 150 Lbs

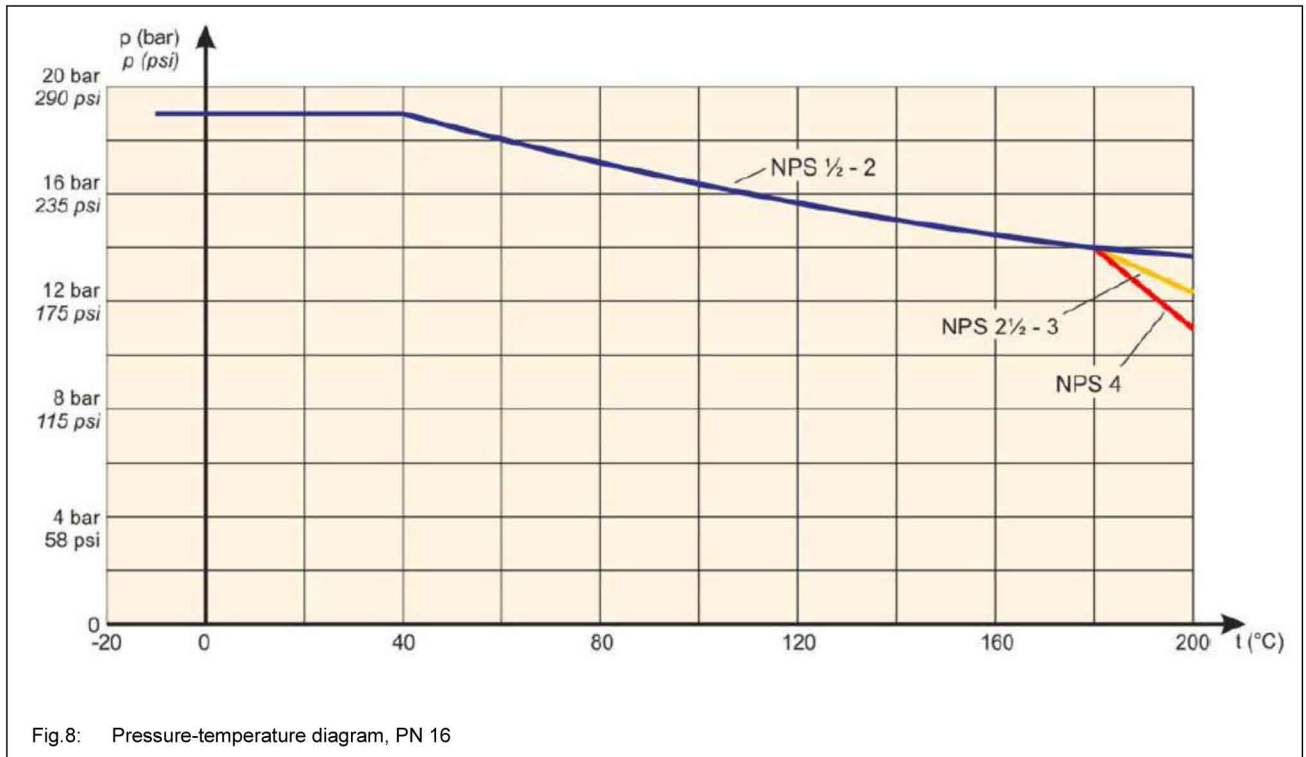

### Pressure-temperature diagram NPS 1/2 to 4" , Class 300 Lbs

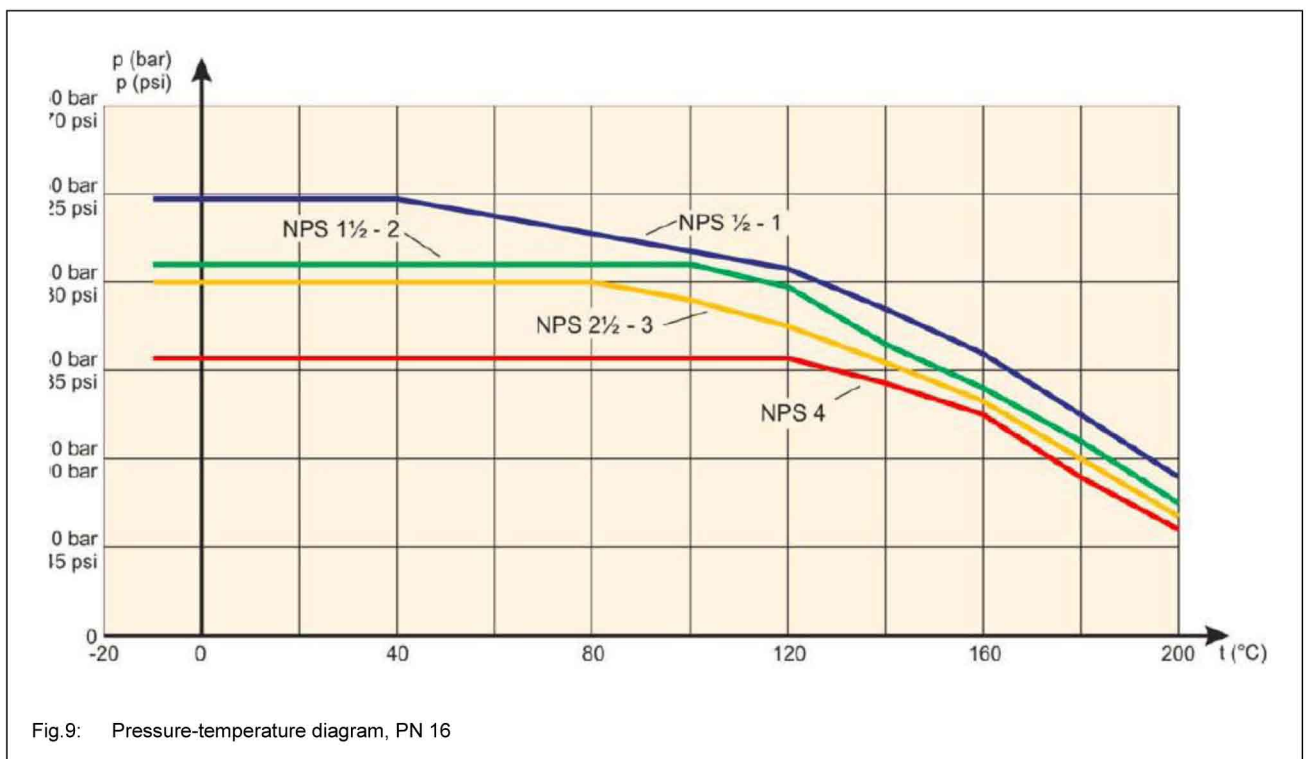

**Table 1 Materials Data**

Type CSFB-2M Series		DIN	ANSI
Main body		WN1.4408 / WN1.0619	A351CF8M
Side body		WN1.4408 / WN1.0619	A351CF8M
Ball		CF3M/316L	
Shaft		CF3M/316L	
Seat rings		TFM (PTFE)	
Spring washer		316L encapsulated in white PTFE	
Packing	Chemical version	PTFE	
	Fire-Safe version	Graphite	
Upper bearing bushing		PTFE with 25% glass	
Lower bearing bushing		PTFE with 25% carbon	
Body sealing	Chemical version	PTFE	
	Fire-Safe version	316L+Graphite	

**Table 2 General technical data**

TypeCSFB-2M Series	DIN	ANSI
Nominal Size	DN 15 to 100, 150, 200	NPS 1/2 40 4, 6, 8
Nominal pressure	PN 16 or 40	Class 150 or 300
Temperature range	-20 to +200°C (Optional -60 / -80°C)	
Ball sealing	TFM (PTFE)	
Leakage rate	Class VI	
Flanges	DIN EN 1092	ASME B16.34 and B16.5
Packing	Normal PTFE V-ring packing loaded by spring washers; Fire-Safe Graphite	

**Table 3 Torque and breakaway torques, KVS and CV coefficients**

DN	NPS	Kvs	CV	Md max. in NM	Md in NM	Mdl in NM			
						Differential pressure Δ P in bar			
						0	6	16	40
15	1/2"	9	10.5	60	3	7.1	7.1	12.9	15.7
20	3/4"	16	18.6	240	5	14.3	14.3	25.7	40.1
25	1"	25	29	240	5	14.3	14.3	25.7	40.1
32	1 1/4"	50	59	450	10	21.6	21.6	42.5	58.6
40	1 1/2"	64	75	450	10	28.6	28.6	50.1	74.4
50	2"	100	115	450	10	42.9	47.2	60.1	104.4
65	2 1/2"	169	196	450	20	64.4	70.1	93.0	164.5
80	3"	256	298	750	25	85.8	94.4	123.0	206.6
100	4"	400	465	750	40	128.7	150.1	200.2	359.0
150	6"	833	972	1200	80	310.5	400.8	/	/
200	8"	1522	1776	1600	180	489.2	572.7	/	/



**Table 4 Dimensions and weights**

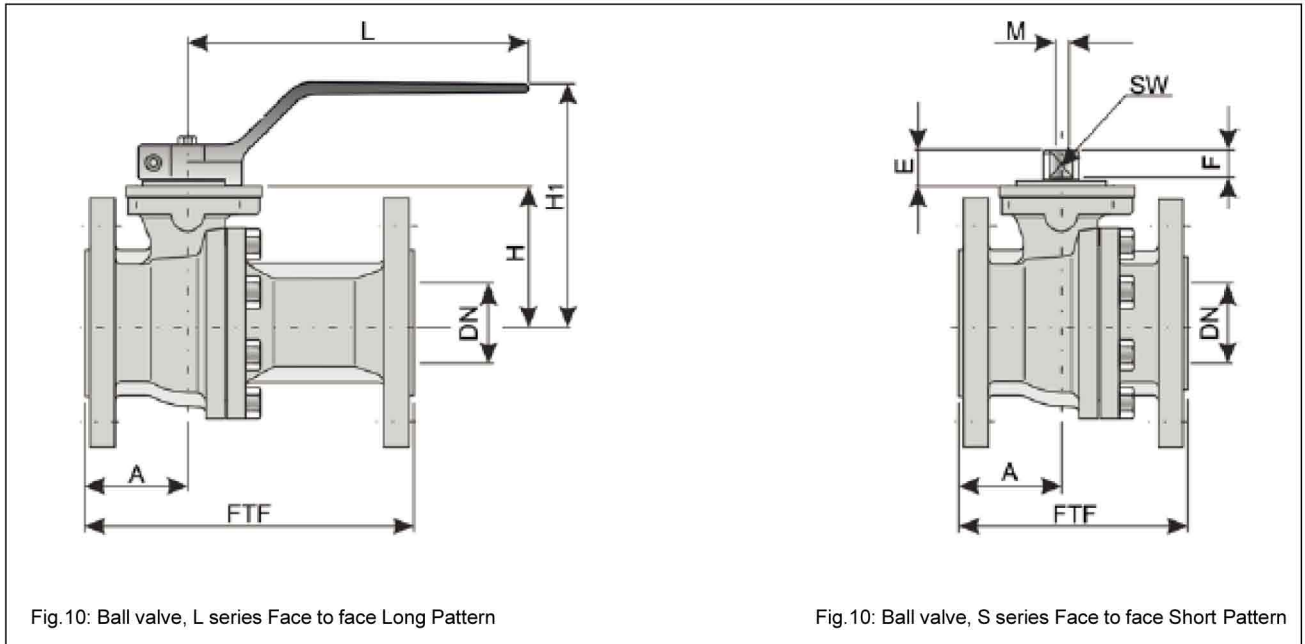

**DIN version**

DN		15	20	25	32	40	50	65		80	100		150	200
PN		40						16	40	40	16	40	16	16
FTF	Long	130	150	160	180	200	230	290		310	350		/	/
	Short	115	120	125	130	140	150	170		180	190		350	400
A		50	56	56	47	62.5	65.5	72		72.5	82.5		129	165.5
E		13	19	19	24.2	22	22	22		26	26		58.2	74.2
F		9	14	14	16.2	17	17	17		19	19		32.5	48
H		46.5	58	58	/	83	91	104.5		130.5	143.5		330	400
H1		98.5	109.5	109.5	136	143.5	151.5	165		177	190		270	/
L		151	155	155	188	207	207	207		350	350		700	/
M		M5	M6	M6	M6	M6	M6	M6		M8	M8		M12	M14
SW		9	14	14	11	17	17	17		19	19		24	36
DIN/ISO conection		F03	F05	F05	F05	F07	F07	F07		F10	F10		F12	F14
Weight in Kgs	Long	2.6	4.5	5	7.7	9	12	15	15	28	48	51	/	/
	Short	2	4	4	7.2	7.5	10	13	13	23	33	35	86	135

**ANSI version**

DN		1/2	3/4	1	1 1/4	1 1/2	2	2 1/2	3	4	6	8
FTF	Class150	108	115	127	140	165	178	190	203	229	394	457
	Class300	140	152	165	/	190	216	241	283	305	/	/
A		46.5	56	54		62.5	65.5	72	79.5	120		
E		13	13	19	11	22	22	22	26	26	27	37
F		9	9.5	14		17	17	17	19	19		
H		46.5	47.5	58	74	83	91	101.5	130.5	143	201	259
H1		98.5	109.5	109.5	108	143.5	151.5	161.5	177	189.5	248	304
L		151	161	155	153	207	207	207	350	350	708	920
M		M5	M5	M6	M6	M6	M6	M6	M8	M8	M12	M14
SW		9	9	14	11	17	17	17	19	19	27	36
DIN/ISO conection		F03	F04	F05	F05	F07	F07	F07	F10	F10	F12	F14
Weight in Kgs	Class150	2.5	2.7	4	7.7	8	9	17.2	20	42	/	/
	Class300	3	3.7	5	7.2	9	11	19.2	25	51.3	/	/

## Article Code

Type CSFB-2M-	Std. Version	Pattern	Pressure class	Body material	Seat material	Packing material	DN
2-Piece Full Part Ball	<b>D</b> – DIN version	<b>L</b> – Long	<b>1</b> – PN16	<b>1</b> – Stainless	<b>1</b> – PTFE	<b>1</b> – PTFE	
	<b>S</b> – ANSI version	<b>S</b> - Short	<b>2</b> – PN40	<b>2</b> – Carbon steel	<b>2</b> – 316ss+Graph.	<b>2</b> - Graphite	
			<b>5</b> – 150lbs				
			<b>6</b> – 300lbs				

### Example:

Type CSFB-2M-DL1111-050

Specifications subject to change without notice

## Thread Connection 1-Piece Type CSFB-1M

### General

Size DN08 to 80 (NPS 1/4 to 3)  
 Body and Ball material CF8M  
 BSP & NPT thread  
 Full bore

### Application

Full port ball valves for process engineering and industrial applications and Utility lines (water, air)

### Components Material Data

Item	Qty.	Description	Material
03	1	Body	CF8M
04	1	Stem thrust seal	PTFE
05	1	Stem	316L
06	3	Stem packing	PTFE
08	2	Seat	PTFE
09	1	Ball	CF8M
10	1	Body connector	CF8M
14	1	Body seal	PTFE
15	1	Handle	304
16	1	Stem nut	304
18	1	Gland nut	304
22	1	Stem washer	304

### Dimensions in mm

DN	NPS	§ A	D	E	F	N	P
8	1/4	11.6	52	56	102	12.7	28.5
12	3/8	12.7	52	56	102	12.7	28.5
15	1/2	15	58	65	132	12.7	28.5
20	3/4	20	67	68	132	22.4	35
25	1	25	78	79	153	22.4	35
32	1 1/4	32	90	84	153	25.4	38.1
40	1 1/2	38	104	94	183	25.4	38.1
50	2	50	127.5	100	183	25.4	38.1
65	2 1/2	65	158	135	246	30	70
80	3	80	186	145	246	30	70

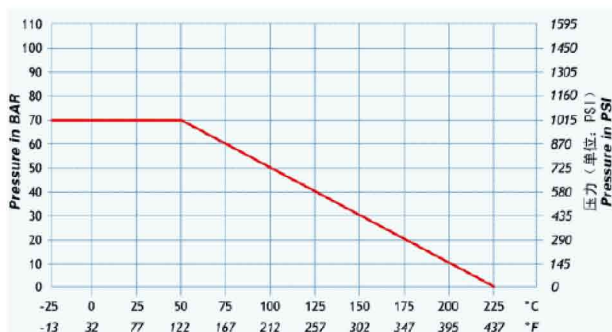

Fig.1 Type CSFB-1M 1-Piece Ball Valve

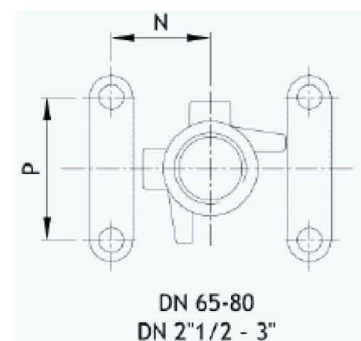
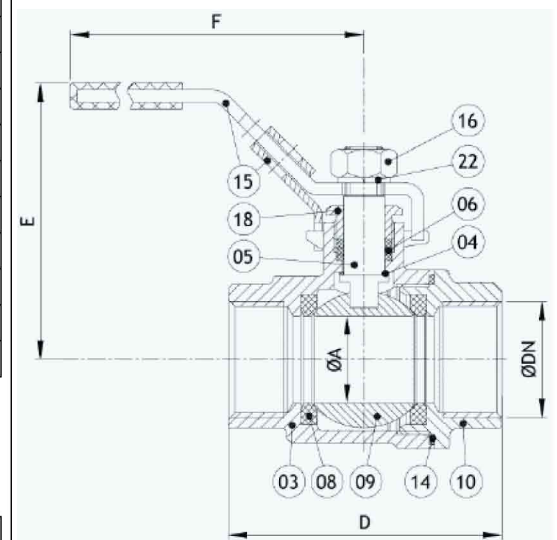

Fig.2 Type CSFB-1M Component and Dimensions



# Thread Connection 3-Piece Type CSFB-3M

## General

Size DN08 to 100 (NPS 1/4 to 4)  
Body and Ball material CF8M  
BSP & NPT thread Full bore

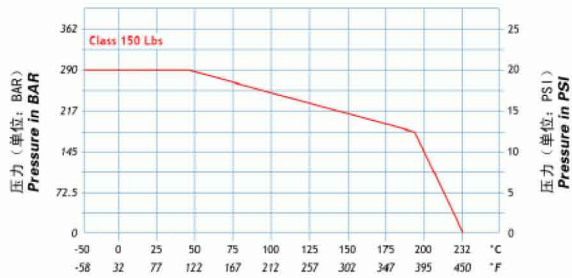

Fig.1 Type CSFB-3M 3-Piece Ball Valve

## Components and Dimensions Data

Item	Qty	Description	Material										
03	1	Body	CF8M										
04	1	Stem thrust seal	PTFE										
05	1	Stem	316L										
06	3	Stem packing	PTFE										
8	2	Seat	PTFE	DN	NPS	φ A	D	E	F	φ H	L	M	ISO
09	1	Ball	CF8M	8	1/4	11.6	58	56	102	40.5	15	5	F03
10	2	Cape	CF8M	12	3/8	12.7	58	56	102	40.5	15	5	F03
13	4	Bolt DN1/4 to 2 1/2	304	15	1/2	15	63	65	123	47	16	6.5	F03
	6	Bolt DN3 to 4	304	20	3/4	20	73	67	123	53.5	16	6.5	F03
14	2	Gasket	PTFE	25	1	25	85	79	153	59.6	21	8	F04
15	1	Handle	304	32	1 1/4	32	96	84	153	74.2	21	8	F04
16	1	Stem nut	304	40	1 1/2	38	114	92	183	84	25	9.5	F05
17a	4	Nut screw DN1/4 to 2 1/2	304	50	2	50	134	99	183	101	29	9.5	F05
	6	Nut screw DN3 to 4	304	65	2 1/2	65	180	136	246	132	40	12	F07
22	1	Spring washer	304	80	3	80	200	146	246	161.5	48	12	F07
24	1	Gland	304	100	4	100	228	168	503	191	33	12	F07

